



**STEEL BUILDINGS**  
A **NUCOR** Company

## STRUCTURAL CALCULATIONS

**Project Name:** Rob Kerth Ice Land  
**NBG Project #:** C22B0182A

### INDEX

<b>DESIGN LOADS &amp; REACTION</b> .....	A/0-11
<b>FLOOR PLAN</b> .....	B/1
<b>SHEETING PLAN</b> .....	C/1-2
<b>SECONDARY FRAMING DESIGN</b> .....	D/1-19
<b>ROOF DESIGN</b> .....	D/1-7
<b>SIDEWALL DESIGN</b> .....	D/8-10
<b>ENDWALL DESIGN</b> .....	D/11-13
<b>CROSS-SECTIONS</b> .....	D/14-18
<b>RIGID FRAME DESIGN</b> .....	F/1-20
<b>FRAME LINE 1,7 (E01)</b> .....	F/1-9
<b>FRAME LINE 2-6 (F01)</b> .....	F/10-20
<b>LONGITUDINAL BRACING</b> .....	G/1-8
<b>ROOF AND WALL DESIGN</b> .....	G/1-8
<b>SPECIAL FRAMING DESIGN</b> .....	H/1-2
<b>HANG POST DESIGN</b> .....	H/1-2



1700 E. Louise Avenue  
Lathrop, CA 95330

Phone: 209-983-0910

Tuesday, August 23, 2022

R.C. Patterson, Inc.  
2505 Delmar Avenue  
Penryn, CA 95663

Project Name: Rob Kerth Ice Land

Buildings: A->105'-0"x147'-6"x20'-0"(RCG, 1:12);

Attn.: BOB PATTERSON

Project Location: Sacramento, CA 95815

Project Number: C22B0182A

-----  
This Letter of Design Certification ensures that the materials furnished by the metal building supplier are designed in accordance with the information specified to the metal building supplier on the order documents and summarized by the loading information listed below. The Project Engineer of Record (not the metal building supplier) is responsible for verifying that the building code and design loads meet any and all applicable local requirements.

The Professional Engineer whose seal appears on this Letter of Certification is employed by the metal building manufacturer, a Member of MBMA, and does not serve as or represent the Engineer of Record for this project and shall not be construed as such.

-----  
**DESIGN LOAD CRITERIA:**

Structural Loads Applied in General Accordance with: California (CBC 2019)

Risk Category: III - Substantial Hazards

-----  
**PROJECT-WIDE LOADING INFORMATION:**

Ground Snow Load: 0.00 psf      Snow Exposure Factor, Ce: 1.00      Snow Imp. Factor, Is: 1.10

Roof Live Load: 20.00 psf      Reducible as per code      Rainfall Intensity: 4 in/hr

Design Wind Velocity: 110 mph      Nominal Design Wind Velocity: 85 mph      \*\*\*C&C Wind: 26psf / -35psf

Is Roof to meet UL 90 Requirements?: No      Wind Exposure: C

Seismic Criteria: Ss:0.539 S1:0.246      \*No ground snow included in seismic calculation

Design Sds / Sd1: 0.492 / 0.346      Analysis Procedure: Equivalent Lateral Force Procedure

Seis. Imp. Factor, Ie: 1.25      Long. SFRS: Ord. Concentrically Braced Frame

Seis. Design Category: D      Site Class: D      Lat. SFRS: Ord. Moment Frame

-----  
**BUILDING-SPECIFIC LOADING INFORMATION:**

Bldg	Roof Dead (psf)*	Collateral Dead		Snow Coefficient		Snow Load (psf)		Wind		Seismic		
		Pri (psf)	Sec (psf)	Ct	Cs	Ps (psf)	**Pm (psf)	Enclosure	GCpi	R	Cs	V (kips)
A	2.50	5.00	5.00	1.20	1.00	0.00	0.00	Enclosed	±0.18	3.25	0.189	37.72

\*Primary Structural Not Included

\*\*Pm is based on the minimum roof snow load calculated per building code or the contract-specified roof snow load, whichever is greater. This value, Pm, is only applied in combination with Dead and Collateral Loads. Roof Snow in other loading conditions is determined per the specified Building Code.

\*\*\*Design wind pressures to be used for wall exterior component and cladding materials not provided by Metal Building Supplier

**Mezzanine Information:**

Floor Dead Load: N/A

Floor Collateral Load: N/A

Floor Live Load: N/A

**Crane Information:**

No cranes on building.

**Roof-Top Unit Information:**

No roof-top units on building.

-----  
The design of structural members supporting roof gravity loads is controlled by the more critical effect of roof live load or roof snow applied in accordance with the governing building code.

**DESIGN STANDARDS REFERENCED:**

- AISC Specification for Structural Steel Buildings - Steel Construction Manual, 15th Edition, ©2017.
- AISI North-American Spec. for the Design of Cold-Formed Steel Structures, ©2016 Edition.
- IBC codes are designed in accordance with ASCE7-16 Edition.
- MBMA Metal Building Systems Manual, Latest Edition.
- AWS Latest Edition of Structural Welding Code.
- No buyout structural components provided on this project.

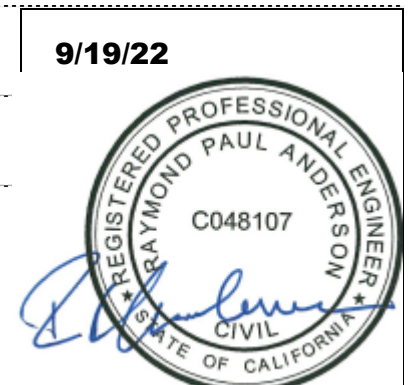

Professional Seal



Special notes to be placed on Erection Drawing Cover Sheet:

**WO7 - Wall by Others Designed to Accommodate Story Drift:**

The concrete/masonry wall designer is responsible for designing and detailing the wall system by others to accommodate the lateral and longitudinal drifts as indicated.

**WO10 - Wall Panel Loads Self-Supported Masonry:**

The metal building manufacturer's wall panels above the top of the masonry/concrete walls must be attached to the walls with a spacing as shown. The masonry/concrete walls, as well as the fasteners attaching the metal building manufacturer's wall panels to the masonry/concrete walls are designed and provided by others (not by the metal building manufacturer). The masonry/concrete wall is self-supporting, and must be designed to support the loads as shown

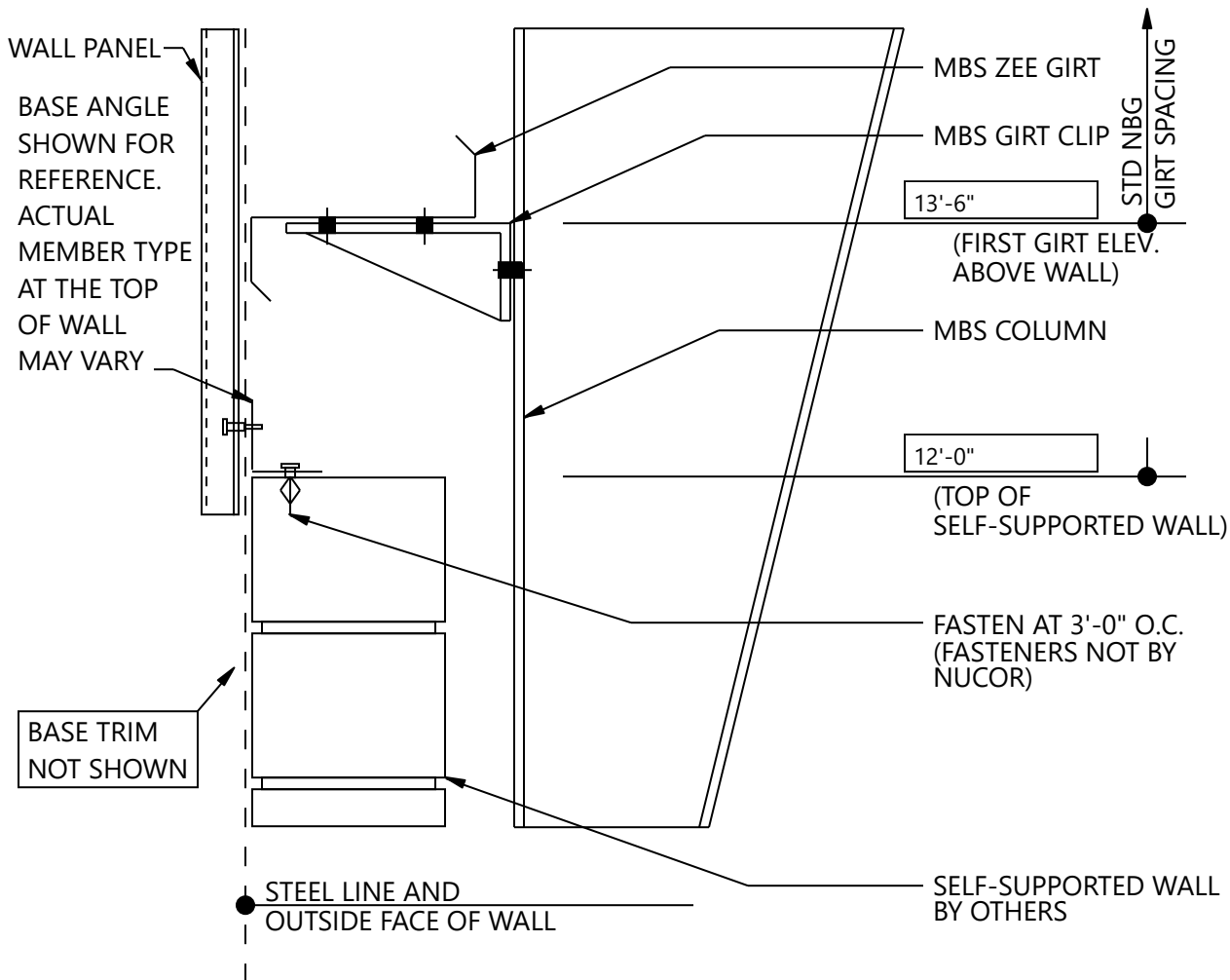

**MBS WALL PANEL LOADS  
 SELF-SUPPORTED WALL BY OTHERS**

WO10



**DESIGN PARAMETERS**

Job No. : C22B0182A Sheet : A - 1  
 Customer : Rob Kerth Ice Land Location: Sacramento, Ca  
 Designed by : VP Builder: R.C. Patterson, Inc.  
 Checked by : **RA 8/30/22**  
 Date : 24-Aug-2022 Revision : 01

**STRUCTURE DESCRIPTION**

Frame Type : Clear Span  
 Building Width : 105.00 ft.  
 Building Length : 147.50 ft.  
 Eave Height : 20.00 ft.  
 Max. Bay Spacing : 25.00 ft.  
 Roof Slope : 1.000 in. / ft.

**BASIC LOADS**

Building Code : CBC 2019 Risk Category : III  
 Roof Live Load : 20 psf Tributary Reduction : Yes  
 Frame Live Load : 12 psf  
 Wind Load  
 Wind Speed, V : 110 mph Enclosure Condition : Enclosed  
 V<sub>asd</sub> : 85 mph Exposure : C  
 Seismic Load  
 Design Category : D S<sub>S</sub> : 53.90% S<sub>I</sub> : 24.60%  
 Importance : 1.25 S<sub>DS</sub> : 0.49 S<sub>DI</sub> : 0.35  
 Site Class : D R<sub>Trans</sub> : 3.50 / Ω<sub>o</sub> : 2.50 C<sub>S-Trans</sub> : 0.18  
 R<sub>Long</sub> : 3.25 / Ω<sub>o</sub> : 2.00 C<sub>S-Long</sub> : 0.19  
 Snow Load  
 Roof Snow : 0 psf Ce : 1.0 Ct : 1.2  
 Ground Snow : 0 psf  
 Importance : 1.10  
 Collateral Load : 5.0 psf  
 Dead Load : 5.0 psf (Total) Frame Wt: 2.5 psf  
 Purlins: 1.0 psf  
 Panels: 1.0 psf  
 Misc.: 0.5 psf

**OTHER LOADS**

**REVISIONS**

\*\*\* This structure is designed in compliance with CBC Steel Buildings specifications and standards utilizing the pertinent provisions and recommendations of the American Institute of Steel Construction (AISC), International Code Council (ICC), American Iron and Steel Institute (AISI), the Metal Building Manufacturer's Association (MBMA) and their publications. \*\*\*



# NUCOR BUILDINGS GROUP

Job # : C22B0182A  
 File : E01.nfr  
 App Version : 1.6.127.0

Job Name : Nucor Buildings Group  
 Designer : BG\Viviana.Perez  
 Date : 8/23/2022

Frame : A-2

## DESIGN SUMMARY - REACTIONS BY LOAD CASE REPORT

## FRAME LINE 1,7

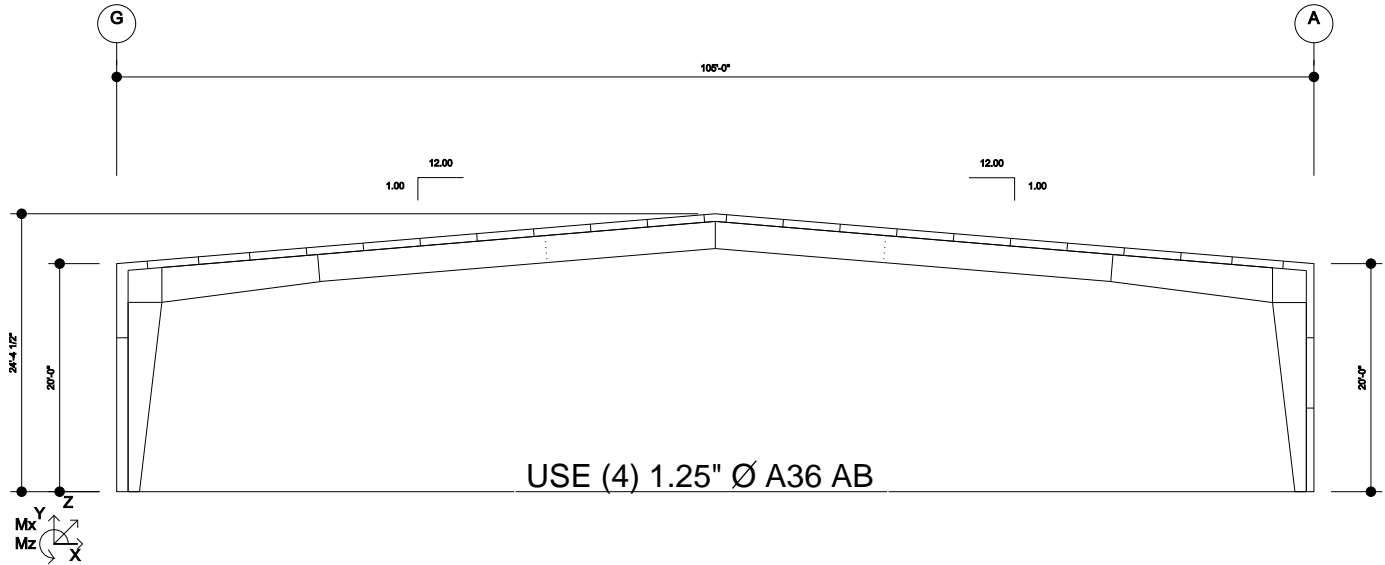

Member	X (kips)	Y (kips)	Z (kips)	Mx (kip-ft)	Mz (kip-ft)	Member	X (kips)	Y (kips)	Z (kips)	Mx (kip-ft)	Mz (kip-ft)
LOAD CASE 1 - DEAD						LOAD CASE 2 - COLLATERAL					
COL01	5	6	0	0	0	COL01	3	4	0	0	0
COL02	-5	6	0	0	0	COL02	-3	4	0	0	0
LOAD CASE 3 - ROOF LIVE						LOAD CASE 4 - WIND CASE 1 TO RIGHT					
COL01	8	9	0	0	0	COL01	-11	-14	0	0	0
COL02	-8	9	0	0	0	COL02	7	-8	0	0	0
LOAD CASE 5 - WIND CASE 1 TO LEFT						LOAD CASE 6 - WIND CASE 2 TO RIGHT					
COL01	-8	-8	0	0	0	COL01	-16	-19	0	0	0
COL02	12	-13	0	0	0	COL02	12	-14	0	0	0
LOAD CASE 7 - WIND CASE 2 TO LEFT						LOAD CASE 8 - LONG. WIND 1 TO BACK					
COL01	-12	-14	0	0	0	COL01	-9	-13	0	0	0
COL02	16	-19	0	0	0	COL02	9	-9	0	0	0
LOAD CASE 9 - LONG. WIND 1 TO FRONT						LOAD CASE 10 - LONG. WIND 2 TO BACK					
COL01	-9	-9	0	0	0	COL01	-13	-19	0	0	0
COL02	8	-13	0	0	0	COL02	13	-14	0	0	0
LOAD CASE 11 - LONG. WIND 2 TO FRONT						LOAD CASE 12 - SEISMIC TO RIGHT					
COL01	-14	-15	0	0	0	COL01	-2	-1	0	0	0
COL02	13	-19	0	0	0	COL02	-2	1	0	0	0
LOAD CASE 13 - SEISMIC TO LEFT											
COL01	2	1	0	0	0						
COL02	2	-1	0	0	0						

**NOTES:**

- ALL WIND REACTIONS SHOWN IN THE TABLE ABOVE ARE BASED ON ULTIMATE DESIGN WIND SPEED AND ARE UNFACTORED.
- SEISMIC REACTIONS ARE DUE TO BASE SHEAR. THE REDUNDANCY FACTOR AND THE OVERSTRENGTH FACTOR HAVE NOT BEEN INCLUDED IN THE REACTIONS SHOWN.

# NUCOR BUILDINGS GROUP

Job # : C22B0182A  
 File : F01a.nfr  
 App Version : 1.6.127.0

Job Name : Rob Kerth Iceland  
 Designer : BG\Viviana.Perez  
 Date : 8/23/2022

Frame : A-3

## DESIGN SUMMARY - REACTIONS BY LOAD CASE REPORT

## FRAME LINE 2-6

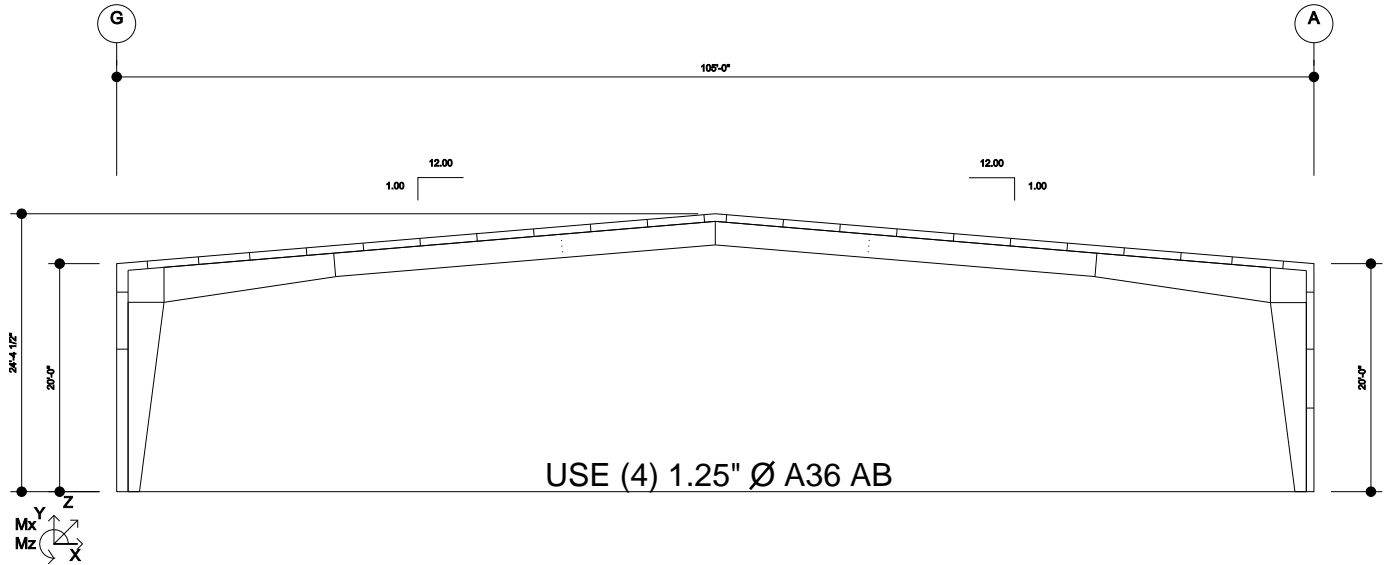

Member	X (kips)	Y (kips)	Z (kips)	Mx (kip-ft)	Mz (kip-ft)	Member	X (kips)	Y (kips)	Z (kips)	Mx (kip-ft)	Mz (kip-ft)
LOAD CASE 1 - DEAD						LOAD CASE 2 - COLLATERAL					
COL01	5	6	0	0	0	COL01	7	7	0	0	0
COL02	-5	6	0	0	0	COL02	-7	7	0	0	0
LOAD CASE 3 - ROOF LIVE						LOAD CASE 4 - WIND CASE 1 TO RIGHT					
COL01	15	17	0	0	0	COL01	-15	-16	0	0	0
COL02	-15	17	0	0	0	COL02	8	-8	0	0	0
LOAD CASE 5 - WIND CASE 1 TO LEFT						LOAD CASE 6 - WIND CASE 2 TO RIGHT					
COL01	-8	-8	0	0	0	COL01	-24	-27	0	0	0
COL02	16	-16	0	0	0	COL02	17	-20	0	0	0
LOAD CASE 7 - WIND CASE 2 TO LEFT						LOAD CASE 8 - LONG. WIND 1 TO BACK					
COL01	-17	-20	0	0	0	COL01	-10	-15	0	0	0
COL02	24	-27	0	0	0	COL02	10	-9	0	0	0
LOAD CASE 9 - LONG. WIND 1 TO FRONT						LOAD CASE 10 - LONG. WIND 2 TO BACK					
COL01	-10	-9	0	0	0	COL01	-19	-26	0	0	0
COL02	9	-14	0	0	0	COL02	19	-21	0	0	0
LOAD CASE 11 - LONG. WIND 2 TO FRONT						LOAD CASE 12 - SEISMIC TO RIGHT					
COL01	-20	-21	0	0	0	COL01	-3	-2	0	0	0
COL02	18	-26	0	0	0	COL02	-3	2	0	0	0
LOAD CASE 13 - SEISMIC TO LEFT											
COL01	3	2	0	0	0						
COL02	3	-2	0	0	0						

**NOTES:**

- ALL WIND REACTIONS SHOWN IN THE TABLE ABOVE ARE BASED ON ULTIMATE DESIGN WIND SPEED AND ARE UNFACTORED.
- SEISMIC REACTIONS ARE DUE TO BASE SHEAR. THE REDUNDANCY FACTOR AND THE OVERSTRENGTH FACTOR HAVE NOT BEEN INCLUDED IN THE REACTIONS SHOWN.

## REACTION SCHEMATICS

(All reactions are in kips)

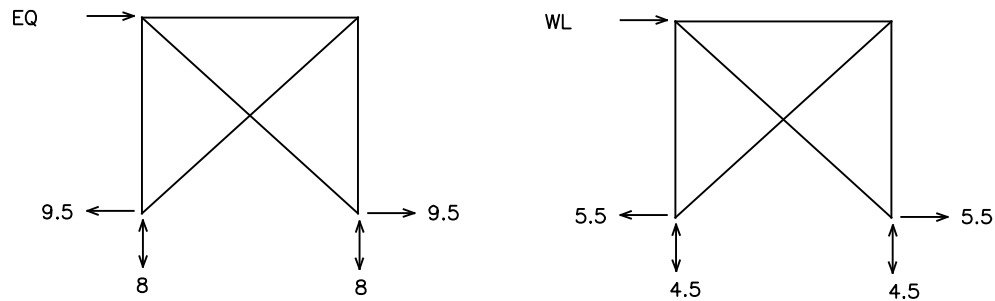

BRACING REACTION SIDEWALL A,G (2-3), (5-6)

NOTES:

1. ALL WIND REACTIONS ARE BASED ON ULTIMATE DESIGN WIND SPEED AND ARE UNFACTORED.
2. SEISMIC REACTIONS ARE DUE TO BASE SHEAR. THE REDUNDANCY FACTOR AND THE OVERSTRENGTH FACTOR HAVE NOT BEEN INCLUDED IN THE REACTIONS SHOWN.
3. BRACING REACTIONS MUST BE COMBINED WITH MAIN FRAME REACTIONS AS REQUIRED BY CODE.



Wind Loading Continued...

**Components and Cladding, Roofs**

Applicable Roof Slope Angle = 4.76 deg

0.6h = 12.00 ft.

0.2h = 4.00 ft.

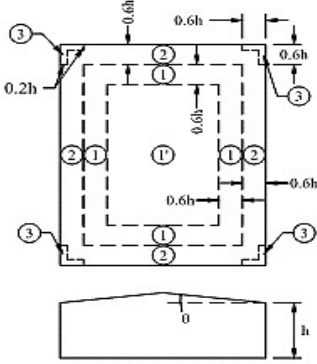

Item	Tributary Area (ft <sup>2</sup> )	Pressure All (psf)	Suction in Zones					
			1' (psf)	1 (psf)	2 (psf)	3 (psf)	---	---
Purlin/Joist	188	16.00	-22.39	-32.18	-42.86	-48.21	---	---
Panel	5	16.00	-25.65	-44.64	-58.89	-80.26	---	---
Fastener	5	16.00	-25.65	-44.64	-58.89	-80.26	---	---
<i>Values Below are for the Overhang Portion of the Roof</i>								
Purlin/Joist	188	---	-36.68	-36.68	-37.52	-42.86	---	---
Panel	5	---	-44.64	-44.64	-58.89	-80.26	---	---
Fastener	5	---	-44.64	-44.64	-58.89	-80.26	---	---

**Components and Cladding, Below-Eave Canopy**

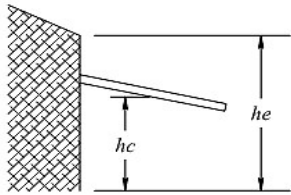

he : Average Eave Height  
hc : Average Canopy Elevation

Item	Tributary Area (ft <sup>2</sup> )	Pressure Total (psf)	Uplift Total (psf) For Various Canopy Elevations		
			hc ≤ 10 ft	Otherwise	hc ≥ 18 ft
Purlin / Joist	188	16.00	-16.00	-16.00	-27.31
Panel	5	21.37	-16.00	-21.37	-33.24
Fastener	5	21.37	-16.00	-21.37	-33.24

**Main Wind Force Resisting Systems (Transverse Wind Direction)**

Applicable Roof Slope Angle = 4.76 deg

a = 8.00 ft.

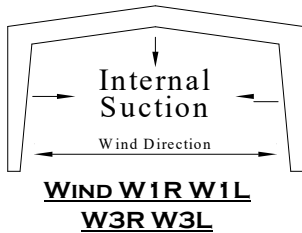

Item	Transverse Wind Direction							
	W1R	W1L	W2R	W2L	W3R	W3L	W4R	W4L
C1: Load, (psf)	0.58	-0.11	0.22	-0.47	---	---	---	---
C2: Load, (psf)	-0.51	-0.19	-0.87	-0.55	---	---	---	---
C3: Load, (psf)	-12.11	-4.51	-20.66	-13.06	---	---	---	---
C4: Load, (psf)	-0.19	-0.51	-0.55	-0.87	---	---	---	---
C5: Load, (psf)	-4.51	-12.11	-13.06	-20.66	---	---	---	---
C6: Load, (psf)	-0.11	0.58	-0.47	0.22	---	---	---	---
Net* (psf)	-2.61	13.77	-11.16	5.22	---	---	---	---
	C5: -0.27	-0.27	-0.63	-0.63	---	---	---	---
	C6: -0.27	-0.27	-0.63	-0.63	---	---	---	---
	Net* (psf)	2.94	2.94	2.94	2.94	---	---	---

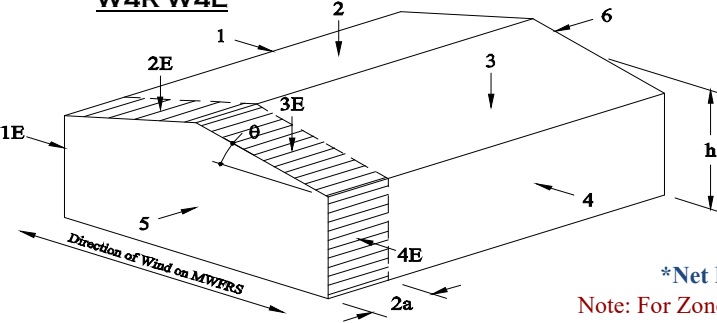

Item	Edge Zone Pressure Coefficients			
	W1R & W3R	W1L & W3L	W2R & W4R	W2L & W4L
C1E: Load, (psf)	0.79	-0.25	0.43	-0.61
C2E: Load, (psf)	-0.89	-0.35	-1.25	-0.71
C3E: Load, (psf)	-21.13	-8.31	-29.68	-16.86
C4E: Load, (psf)	-0.35	-0.89	-0.71	-1.25
	-8.31	-21.13	-16.86	-29.68
	-0.25	0.79	-0.61	0.43
	-5.94	18.76	-14.49	10.21

\*Net Lat < 16 psf. Add additional pressure to windward wall.

Note: For Zone 2/2E or 3/3E; the windward zone width shall be 50.00 ft., while the leeward zone width shall be 55.00 ft. per Figure 28.3-1 note 8.

Wind Loading Continued...

Main Wind Force Resisting Systems (Longitudinal Wind Direction)

Applicable Roof Slope Angle = 4.76 deg  
a = 8.00 ft.

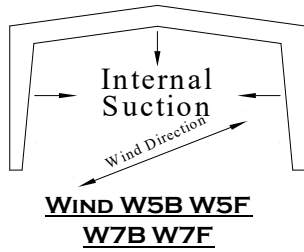

Item	Longitudinal Wind Direction							
	W5B	W5F	W6B	W6F	W7B	W7F	W8B	W8F
C1:	-0.27	-0.27	-0.63	-0.63	---	---	---	---
Load, (psf)	-6.41	-6.41	-14.96	-14.96	---	---	---	---
C2:	-0.51	-0.19	-0.87	-0.55	---	---	---	---
Load, (psf)	-12.11	-4.51	-20.66	-13.06	---	---	---	---
C3:	-0.19	-0.51	-0.55	-0.87	---	---	---	---
Load, (psf)	-4.51	-12.11	-13.06	-20.66	---	---	---	---
C4:	-0.27	-0.27	-0.63	-0.63	---	---	---	---
Load, (psf)	-6.41	-6.41	-14.96	-14.96	---	---	---	---
C1E:	-0.30	-0.30	-0.66	-0.66	---	---	---	---
Load, (psf)	-7.12	-7.12	-15.67	-15.67	---	---	---	---
C2E:	-0.89	-0.35	-1.25	-0.71	---	---	---	---
Load, (psf)	-21.13	-8.31	-29.68	-16.86	---	---	---	---
C3E:	-0.35	-0.89	-0.71	-1.25	---	---	---	---
Load, (psf)	-8.31	-21.13	-16.86	-29.68	---	---	---	---
C4E:	-0.30	-0.30	-0.66	-0.66	---	---	---	---
Load, (psf)	-7.12	-7.12	-15.67	-15.67	---	---	---	---

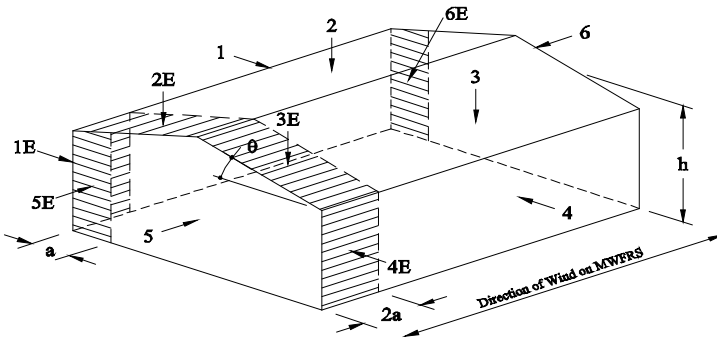

Item	End-Wall Pressure Coefficients			
	W5B & W7B	W5F & W7F	W6B & W8B	W6F & W8F
C5:	0.58	-0.11	0.22	-0.47
Load, (psf)	13.77	-2.61	5.22	-11.16
C6:	-0.11	0.58	-0.47	0.22
Load, (psf)	-2.61	13.77	-11.16	5.22
C5E:	0.79	-0.25	0.43	-0.61
Load, (psf)	18.76	-5.94	10.21	-14.49
C6E:	-0.25	0.79	-0.61	0.43
Load, (psf)	-5.94	18.76	-14.49	10.21

Longitudinal Force Resisted by Bracing: 20.44 kips

Total Longitudinal Net Pressure Applied to Building: 17.55 psf

Total Longitudinal Force Applied to Building: 40.88 kips

**IBC 2018 Seismic Considerations:**

Input Data

Equivalent Lateral Force Procedure (per ASCE 7, Section 12.8)

Spreadsheet Revision Number : 2021.01.20  
 Latest Revision Date : 1/20/2021

**Building Data Input:**

Building A	Building A
Nature of Occupancy	Substantial Hazard
Gable/Single Slope	Gable
Building Width	105.00 feet
Building Length	147.50 feet
Distance to Ridge (from BSW)	52.50 feet
Roof Slope, s:12 (slope to BSW)	1.00 : 12
Low Eave Height (Front SW)	20.00 feet
High Eave Height (Back SW)	20.00 feet
Mean Roof Height	22.19 feet

Project No.:	C22B0182A
Description:	Rob Kerth Ice Land
Engineer:	VP
Date:	8/24/2022

Roof Level Diaphragm	Flexible	*
Mezzanine Level Diaphragm	None	*
Vertical Distribution Required	<input type="checkbox"/>	
Seismic Irregularities Exist	<input type="checkbox"/>	

\*Note: ASCE 7 states "Where diaphragms are not flexible, the design shall include the torsion moment plus the accidental torsional moments caused by an assumed 5% displacement in either direction of the building masses." Due to the configuration of rigid frame metal buildings, accidental torsion is NOT required in the lateral seismic calculations. Thus accidental torsion due to diaphragm rigidity shall only be applied to the longitudinal seismic calcs.

**Seismic Data Input:**

Short period response acceleration, S <sub>s</sub>	S <sub>s</sub> = 0.539
1-second period response acceleration, S <sub>1</sub>	S <sub>1</sub> = 0.246
Site Classification	D

\*\*Note: ASCE 7 Section 11.4.2, states "Where the soil properties are not known in sufficient detail to determine the site class, Site Class D shall be used unless the authority having jurisdiction or geotechnical data determines Site Class E or F soils are present at the site." As a result, Site Class D will be used on nearly all buildings.

**Roof Loading:**

Lateral Frame Self weight (SW)	2.50 psf
Roof Dead Load (RDL)	2.00 psf
Roof Collateral Load (CDL)	5.00 psf
Roof Self Weight (Bracing, Beams etc.)	0.50 psf
Roof Snow (Pf)	0.00 psf

\*\*\*Note: 20% of flat roof snow load is used in seismic dead load calculations when the flat roof snow load is greater than 30 psf. DO NOT include any snow drift loads in seismic dead load.

\*\*\*\*Note: Full Height Hardwall is applied at mean roof height (mrh) at Endwalls. Enter the height required to account for the full dead load of the wall. For Parapets below the Ridge Height on Endwalls the actual Top Elevation must be adjusted.

**Exterior Wall #1 (Left EW) Loads:**

<input type="radio"/> Full Height Wall	<input type="radio"/> Full Height Wall w/ Parapet
<input checked="" type="radio"/> Partial Height Hardwall	<input type="radio"/> Partial Height Hardwall w/ Parapet
<input checked="" type="checkbox"/> Exclude Wall in Lateral Seismic Calculations. (Shear Wall Supports Self Weight)	
Wall Length	105.00 feet
Top Elevation	22.19 feet ****
Upper Wall Weight	2.50 psf
Top of Masonry Elevation	12.00 feet
Lower Wall Weight	55.00 psf

**Exterior Wall #3 (Right EW) Loads:**

<input type="radio"/> Full Height Wall	<input type="radio"/> Full Height Wall w/ Parapet
<input checked="" type="radio"/> Partial Height Hardwall	<input type="radio"/> Partial Height Hardwall w/ Parapet
<input checked="" type="checkbox"/> Exclude Wall in Lateral Seismic Calculations. (Shear Wall Supports Self Weight)	
Wall Length	105.00 feet
Top Elevation	22.19 feet ****
Upper Wall Weight	2.50 psf
Top of Masonry Elevation	12.00 feet
Lower Wall Weight	55.00 psf

**Exterior Wall #2 (Front SW) Loads:**

<input type="radio"/> Full Height Wall	<input type="radio"/> Full Height Wall w/ Parapet
<input checked="" type="radio"/> Partial Height Hardwall	<input type="radio"/> Partial Height Hardwall w/ Parapet
<input checked="" type="checkbox"/> Exclude Wall in Longitudinal Seismic Calculations. (Shear Wall Supports Self Weight)	
Top Elevation	20.00 feet
Upper Wall Weight	2.50 psf
Top of Masonry Elevation	12.00 feet
Lower Wall Weight	55.00 psf

**Exterior Wall #4 (Back SW) Loads:**

<input checked="" type="radio"/> Full Height Wall	<input type="radio"/> Full Height Wall w/ Parapet
<input type="radio"/> Partial Height Hardwall	<input type="radio"/> Partial Height Hardwall w/ Parapet
<input checked="" type="checkbox"/> Exclude Wall in Longitudinal Seismic Calculations. (Shear Wall Supports Self Weight)	
Top Elevation	20.00 feet
Wall Weight	2.50 psf

**Interior Wall #5 (Partition) Loads:**

<input checked="" type="radio"/> Full Height Wall	<input type="radio"/> Full Height Wall w/ Parapet
<input type="radio"/> Partial Height Hardwall	<input type="radio"/> Partial Height Hardwall w/ Parapet
<input checked="" type="checkbox"/> Exclude Wall in Lateral Seismic Calculations. (Shear Wall Supports Self Weight)	
Top Elevation	22.19 feet ****
Wall Weight	0.00 psf

Note: The weight of a concrete or masonry wall may be excluded from the seismic load calculations for lateral / longitudinal seismic force resisting systems, provided that details permit unrestrained movement of the seismic force resisting system relative to the wall. (This exclusion does not apply to metal panel walls, wood, EIFS, or other flexible wall systems that are attached to the building framing at several points.) Per MBMA "Seismic Design Guide for Metal Building Systems.

**IBC 2018 Lateral Seismic Calculations:**

Lateral Calcs. (1)

Equivalent Lateral Force Procedure (per ASCE 7, Section 12.8)

Spreadsheet Revision Number : 2021.01.20  
 Latest Revision Date : 1/20/2021

Frame Description / Location: FL/1,7

Project No.: C22B0182A  
 Description: Rob Kerth Ice Land  
 Engineer : VP  
 Date : 8/24/2022

**Building Data Input Echo:**

Occupancy Category III  
 Seismic Force Resisting System Rigid Frame Ordinary Steel Moment Frames  
 Gable/Single Slope Gable  
 Width 105.00 feet  
 Length 147.50 feet  
 Distance to Ridge 52.50 feet  
 Roof Slope, s:12 1.00 : 12  
 Low Eave Height 20.00 feet  
 High Eave Height 20.00 feet  
 Mean Roof Height 22.19 feet  
 Bay Width 12.60 feet  
 Frame Located at Bay:  
 Left Endwall     Interior Frame  
 Right Endwall     Int. Frame w/ Partition

**Hardwall (SW) Information:**

Wall Length Exterior Wall #2 (Front SW): 12.60 feet  
 Wall Length Exterior Wall #4 (Back SW): 12.60 feet

**Roof Concentrated Load Information:**

Roof concentrated loads:

**Mezzanine Information:**

Is Mez #1 or #2 Considered a Story?   
 Loading Area - Mezzanine #1:   
 Concentrated Loads - Mezzanine #1:   
 Loading Area - Mezzanine #2:   
 Concentrated Loads - Mezzanine #2:

**Crane Information:**

Quantity of Cranes / Bay - Aisle #1:  \*  
 Length of Runway - Aisle #1:  \*\*  
 Quantity of Cranes / Bay - Aisle #2:  \*  
 Length of Runway - Aisle #2:  \*\*  
 Quantity of Cranes / Bay - Aisle #3:  \*  
 Length of Runway - Aisle #3:  \*\*

**Seismic Data Input Echo:**

Short period response acceleration, S<sub>s</sub> 0.539  
 1-second period response acceleration, S<sub>1</sub> 0.246

\*Note: Enter quantity of cranes for one aisle only, DO NOT increase the crane quantities when crane information is used for more than one aisle.

**Seismic Data Output:**

Occupancy Importance Factor, I<sub>e</sub> 1.25  
 Site Coefficient Fa: 1.37  
 Site Coefficient Fv: 2.11  
 Max spectral response for short periods (Eq 11.4-1): 0.738  
 Max spectral response for 1-second period (Eq 11.4-2): 0.519  
 Design spectral response for short periods (Eq 11.4-3): 0.492  
 Design spectral response for 1-second periods (Eq 11.4-4): 0.346  
 Seismic Design Category: D  
 Response Modification Coefficient, R: 3.5 \*\*\*  
 System Overstrength Factor, Ω<sub>o</sub>: 2.5 \*\*\*  
 Deflection Modification Factor, C<sub>d</sub>: 3 \*\*\*  
 Building Period Coefficient, C<sub>t</sub>: 0.028  
 Approximate Fundamental Period, T<sub>a</sub> (Eq 12.8-7): 0.334

\*\*Note: Enter runway length, DO NOT double runway length as other seismic sheets have asked you to do previously.

\*\*\*Note: ASCE 7 - Sections 12.2.3, 12.2.3.1 through 12.2.3.3 states, "Where different seismic force-resisting systems are used in combination to resist seismic forces in the same direction of structural response, other than those combinations considered as dual systems, the more stringent system limitation contained in Table 12.2-1 shall apply." The value of the response modification coefficient, R, used for design in the direction under consideration shall not be greater than the least value of R for any of the systems utilized in that direction. The deflection amplification factor, C<sub>d</sub>, and the over-strength factor, Ω<sub>o</sub>, shall be consistent with R required in that direction; excluding buildings with a risk category of I or II, and flexible diaphragms. In which case, resisting elements are permitted to be designed for the least value of R for each independent line of reference.

Please refer to ASCE 7 12.8.2 and table 12.8-1 for Fundamental Periods for strength design, for seismic story drift checks ONLY there is no upper limit stated

**Seismic Load Output:**

Seismic Base Shear, V (Eq 12.8-1) 3.26 kips  
 Seismic Response Coefficient, C<sub>s</sub> (Eq 12.8-1 to 12.8-6) 0.176  
 Redundancy Factor, ρ 1.30  
 Distribution Exponent, k 0.00

Multistory Distribution						Alt. Roof Weight:	Alt. Panel Load:
Seismic Considerations	Eff. Seismic Weight W <sub>x</sub>	Elevation h <sub>x</sub>	Vertical Dist. Factor, C <sub>vx</sub>	Seismic Force F <sub>x</sub>	Seismic Base Moment M	13.65 psf	0.030 kips/ft
Frame Uniform Loads						Roof Weight:	Panel Load:
Frame Concentrated Loads						Load	Elevation
Roof Loads	13276 lbs	22.19 feet	13276	2.33 kips	51.74 ft-kips	11.60 psf	0.026 kips/ft
Exterior Wall #1 (Left EW) Loads	2674 lbs	17.17 feet 6.00 feet	2674	0.47 kips	8.07 ft-kips	0.507 kips	18.67 feet
Exterior Wall #2 (Front SW) Loads	252 lbs 8316 lbs	16.00 feet 6.00 feet	252 8316	0.04 kips 1.46 kips	0.71 ft-kips 8.76 ft-kips	0.059 kips	18.67 feet
Exterior Wall #4 (Back SW) Loads	630 lbs	10.00 feet	630	0.11 kips	1.11 ft-kips		
Crane Aisle #1	0 lbs	--	--	--	--		
Crane Aisle #2	0 lbs	--	--	--	--		
Crane Aisle #3	0 lbs	--	--	--	--		
Mezzanine #1	0 lbs	--	--	--	--		
Mezzanine #2	0 lbs	--	--	--	--		
<b>Totals</b>	<b>25148 lbs</b>	--	<b>25148</b>	<b>4.42 kips</b>	<b>70.39 ft-kips</b>	<b>Frame Base Shear:</b>	<b>3.262 kips</b>



**IBC 2018 Lateral Seismic Calculations:**

Lateral Calcs. (2)

Equivalent Lateral Force Procedure (per ASCE 7, Section 12.8)

Spreadsheet Revision Number : 2021.01.20

Latest Revision Date : 1/20/2021

Frame Description / Location:

FL/2-6

**Building Data Input Echo:**

Building A

Occupancy Category  
Seismic Force Resisting System  
Gable/Single Slope

III  
Rigid Frame  
Gable

Ordinary Steel Moment Frames

Width  
Length  
Distance to Ridge  
Roof Slope, s:12  
Low Eave Height  
High Eave Height  
Mean Roof Height  
Bay Width

105.00 feet  
147.50 feet  
52.50 feet  
1.00 : 12  
20.00 feet  
20.00 feet  
22.19 feet  
25.00 feet

Frame Located at Bay:

Left Endwall  Interior Frame  
 Right Endwall  Int. Frame w/ Partition

Project No.: C22B0182A  
Description: Rob Kerth Ice Land  
Engineer: VP  
Date: 8/24/2022

**Hardwall (SW) Information:**

Wall Length Exterior Wall #2 (Front SW): 25.00 feet  
Wall Length Exterior Wall #4 (Back SW): 25.00 feet

**Roof Concentrated Load Information:**

Roof concentrated loads:

**Mezzanine Information:**

Is Mez #1 or #2 Considered a Story?  
Loading Area - Mezzanine #1:  
Concentrated Loads - Mezzanine #1:  
  
Loading Area - Mezzanine #2:  
Concentrated Loads - Mezzanine #2:

**Crane Information:**

Quantity of Cranes / Bay - Aisle #1: \*  
Length of Runway - Aisle #1: \*\*  
  
Quantity of Cranes / Bay - Aisle #2: \*  
Length of Runway - Aisle #2: \*\*  
  
Quantity of Cranes / Bay - Aisle #3: \*  
Length of Runway - Aisle #3: \*\*

**Seismic Data Input Echo:**

Short period response acceleration, Ss Ss = 0.539  
1-second period response acceleration, S1 S1 = 0.246

\*Note: Enter quantity of cranes for one aisle only, DO NOT increase the crane quantities when crane information is used for more than one aisle.

**Seismic Data Output:**

Occupancy Importance Factor, Ie 1.25  
Site Coefficient Fa Fa = 1.37  
Site Coefficient Fv Fv = 2.11  
Max spectral response for short periods (Eq 11.4-1): Sms = 0.738  
Max spectral response for 1-second period (Eq 11.4-2): Sm1 = 0.519  
Design spectral response for short periods (Eq 11.4-3): Sds = 0.492  
Design spectral response for 1-second periods (Eq 11.4-4): Sd1 = 0.346  
Seismic Design Category: D  
Response Modification Coefficient, R: 3.5 \*\*\*  
System Overstrength Factor, Ωo: 2.5 \*\*\*  
Deflection Modification Factor, Cd: 3 \*\*\*  
Building Period Coefficient, Ct: 0.028  
Approximate Fundamental Period, Ta (Eq 12.8-7): 0.334

\*\*Note: Enter runway length, DO NOT double runway length as other seismic sheets have asked you to do previously.

\*\*\*Note: ASCE 7 - Sections 12.2.3, 12.2.3.1 through 12.2.3.3 states, "Where different seismic force-resisting systems are used in combination to resist seismic forces in the same direction of structural response, other than those combinations considered as dual systems, the more stringent system limitation contained in Table 12.2-1 shall apply." The value of the response modification coefficient, R, used for design in the direction under consideration shall not be greater than the least value of R for any of the systems utilized in that direction. The deflection amplification factor, Cd, and the over-strength factor, Ωo, shall be consistent with R required in that direction; excluding buildings with a risk category of I or II, and flexible diaphragms. In which case, resisting elements are permitted to be designed for the least value of R for each independent line of reference.

Please refer to ASCE 7 12.8.2 and table 12.8-1 for Fundamental Periods for strength design, for seismic story drift checks ONLY there is no upper limit stated

**Seismic Load Output:**

Seismic Base Shear, V (Eq 12.8-1) 5.75 kips  
Seismic Response Coefficient, Cs (Eq 12.8-1 to 12.8-6) 0.176  
Redundancy Factor, ρ 1.30  
Distribution Exponent, k 0.00

**Multistory Distribution**

Seismic Considerations	Eff. Seismic Weight W <sub>x</sub>	Elevation h <sub>x</sub>	Vertical Dist. Factor, C <sub>vx</sub>	Seismic Force F <sub>x</sub>	Seismic Base Moment M	Alt. Roof Weight:	Alt. Panel Load:
						12.09 psf	0.053 kips/ft
Roof Loads	26341 lbs	22.19 feet	26341	4.63 kips	102.66 ft-kips	Frame Uniform Loads	
Interior Wall #5 (Partition) Loads	0 lbs	--	--	--	--	Roof Weight:	Panel Load:
Exterior Wall #2 (Front SW) Loads	500 lbs 16500 lbs	16.00 feet 6.00 feet	500 16500	0.09 kips 2.90 kips	1.41 ft-kips 17.39 ft-kips	10.03 psf	0.044 kips/ft
Exterior Wall #4 (Back SW) Loads	1250 lbs	10.00 feet	1250	0.22 kips	2.20 ft-kips	Frame Concentrated Loads	
Crane Aisle #1	0 lbs	--	--	--	--	Load	Elevation
Crane Aisle #2	0 lbs	--	--	--	--	1.007 kips	18.67 feet
Crane Aisle #3	0 lbs	--	--	--	--	0.118 kips	18.67 feet
Mezzanine #1	0 lbs	--	--	--	--	--	--
Mezzanine #2	0 lbs	--	--	--	--	--	--
<b>Totals</b>	<b>44591 lbs</b>	<b>--</b>	<b>44591</b>	<b>7.83 kips</b>	<b>123.66 ft-kips</b>	<b>Frame Base Shear:</b>	<b>5.752 kips</b>

**IBC 2018 Longitudinal Seismic Calculations:**  
Equivalent Lateral Force Procedure (per ASCE 7, Section 12.8)

Longitudinal Cales.

Spreadsheet Revision Number : 2021.01.20  
Latest Revision Date : 1/20/2021

<b>Building Data Input Echo:</b>	Building A
Occupancy Category	III
Low SW Force Resisting System	X-Bracing
High SW Force Resisting System	X-Bracing
Gable/Single Slope	Gable
Width	105.00 feet
Length	147.50 feet
Distance to Ridge	52.50 feet
Roof Slope, s:12	1.00 : 12
Low Eave Height	20.00 feet
High Eave Height	20.00 feet
Mean Roof Height	22.19 feet

Ordinary Steel Concentrically Braced Frames

Project No.:	C22B0182A
Description:	Rob Kerth Ice Land
Engineer :	VP
Date :	8/24/2022

**Roof Concentrated Load Information:**

Roof concentrated loads:

**Hardwall Information:**

Wall Length Exterior Wall #2 (Front SW):	147.50 feet
Wall Length Exterior Wall #4 (Back SW):	147.50 feet
Wall Length Interior Wall #5 (Partition):	105.00 feet
Quantity of Partition Walls (Wall #5):	<input type="text"/>

**Mezzanine Information:**

Is Mez #1 or #2 Considered a Story?	<input type="text"/>
Loading Area - Mezzanine #1:	<input type="text"/>
Concentrated Loads - Mezzanine #1:	<input type="text"/>
Loading Area - Mezzanine #2:	<input type="text"/>
Concentrated Loads - Mezzanine #2:	<input type="text"/>

**Crane Information:**

Quantity of Cranes - Aisle #1:	<input type="text"/>	*
Length of Runway - Aisle #1:	<input type="text"/>	
Quantity of Ind. Crane Columns - Aisle #1:	<input type="text"/>	
Quantity of Cranes - Aisle #2:	<input type="text"/>	*
Length of Runway - Aisle #2:	<input type="text"/>	
Quantity of Ind. Crane Columns - Aisle #2:	<input type="text"/>	
Quantity of Cranes - Aisle #3:	<input type="text"/>	*
Length of Runway - Aisle #3:	<input type="text"/>	
Quantity of Ind. Crane Columns - Aisle #3:	<input type="text"/>	

**Seismic Data Input Echo:**

Short period response acceleration, S <sub>s</sub>	S <sub>s</sub> = 0.539
1-second period response acceleration, S <sub>1</sub>	S <sub>1</sub> = 0.246

**Seismic Data Output:**

Occupancy Importance Factor, I <sub>e</sub>	1.25
Site Coefficient Fa:	F <sub>a</sub> = 1.37
Site Coefficient Fv:	F <sub>v</sub> = 2.11
Max spectral response for short periods (Eq 11.4-1):	S <sub>ms</sub> = 0.738
Max spectral response for 1-second period (Eq 11.4-2):	S <sub>m1</sub> = 0.519
Design spectral response for short periods (Eq 11.4-3):	S <sub>ds</sub> = 0.492
Design spectral response for 1-second periods (Eq 11.4-4):	S <sub>d1</sub> = 0.346
Seismic Design Category:	D
Response Modification Coefficient, R:	3.25 **
System Overstrength Factor, Ω <sub>o</sub> :	2 **
Deflection Modification Factor, C <sub>d</sub> :	3.25 **
Building Period Coefficient, C <sub>t</sub> :	0.02
Approximate Fundamental Period, T <sub>a</sub> (Eq 12.8-7):	0.204 <input type="text"/>

\*Note: Enter quantity of cranes for one aisle only, DO NOT increase the crane quantities when crane information is used for more than one aisle.

\*\*Note: ASCE 7 - Sections 12.2.3, 12.2.3.1 through 12.2.3.3 states, "Where different seismic force-resisting systems are used in combination to resist seismic forces in the same direction of structural response, other than those combinations considered as dual systems, the more stringent system limitation contained in Table 12.2-1 shall apply." The value of the response modification coefficient, R, used for design in the direction under consideration shall not be greater than the least value of R for any of the systems utilized in that direction. The deflection amplification factor, C<sub>d</sub>, and the over-strength factor, Ω<sub>o</sub>, shall be consistent with R required in that direction; excluding buildings with a risk category of I or II, and flexible diaphragms. In which case, resisting elements are permitted to be designed for the least value of R for each independent line of resistance.  
Please refer to ASCE 7 12.8.2 and table 12.8-1 for Fundamental Periods for strength design, for seismic story drift checks ONLY there is no upper limit stated

**Seismic Load Output:**

Seismic Base Shear, V (Eq 12.8-1)	37.72 kips	Redundancy Factor, ρ	1.30
Seismic Response Coefficient, C <sub>s</sub> (Eq 12.8-1 to 12.8-6)	0.189	Distribution Exponent, k	0.00

**Multistory Distribution**

Seismic Considerations	Eff. Seismic Weight W <sub>x</sub>	Elevation h <sub>x</sub>	Vertical Dist. Factor, C <sub>vx</sub>	Seismic Force F <sub>x</sub>	Seismic Base Moment M	Bracing Uniform Loads	
Roof Loads	155412 lbs	22.19 feet	155412	29.40 kips	652.31 ft-kips	Roof Snow:	--
Exterior Wall #1 (Left EW) Loads	2674 lbs 69300 lbs	17.17 feet 6.00 feet	2674 69300	0.51 kips 13.11 kips	8.69 ft-kips 78.66 ft-kips	Seismic Dead W:	12.72 psf
Exterior Wall #3 (Right EW) Loads	2674 lbs 69300 lbs	17.17 feet 6.00 feet	2674 69300	0.51 kips 13.11 kips	8.69 ft-kips 78.66 ft-kips	<b>Total Seismic W:</b>	<b>12.72 psf</b>
Interior Wall #5 (Partition) Loads	0 lbs	11.13 feet	--	--	--	<b>Seismic Factor:</b>	<b>0.189</b>
						<b>Bracing Concentrated Loads</b>	
						<b>Load</b>	<b>Elevation</b>
Exterior Wall #2 (Front SW) Loads	2950 lbs	16.00 feet 6.00 feet	2950	0.56 kips	8.93 ft-kips	<b>0.446 kips</b>	<b>20.00 feet</b>
Exterior Wall #4 (Back SW) Loads	0 lbs	10.00 feet	--	--	--	--	--
Crane Aisle #1	0 lbs	--	--	--	--	--	--
Crane Aisle #2	0 lbs	--	--	--	--	--	--
Crane Aisle #3	0 lbs	--	--	--	--	--	--
Mezzanine #1	0 lbs	--	--	--	--	--	--
Mezzanine #2	0 lbs	--	--	--	--	--	--
<b>Totals</b>	<b>302310 lbs</b>	<b>--</b>	<b>302310</b>	<b>57.19 kips</b>	<b>835.94 ft-kips</b>	<b>Bracing Base Shear:</b>	<b>37.720 kips</b>

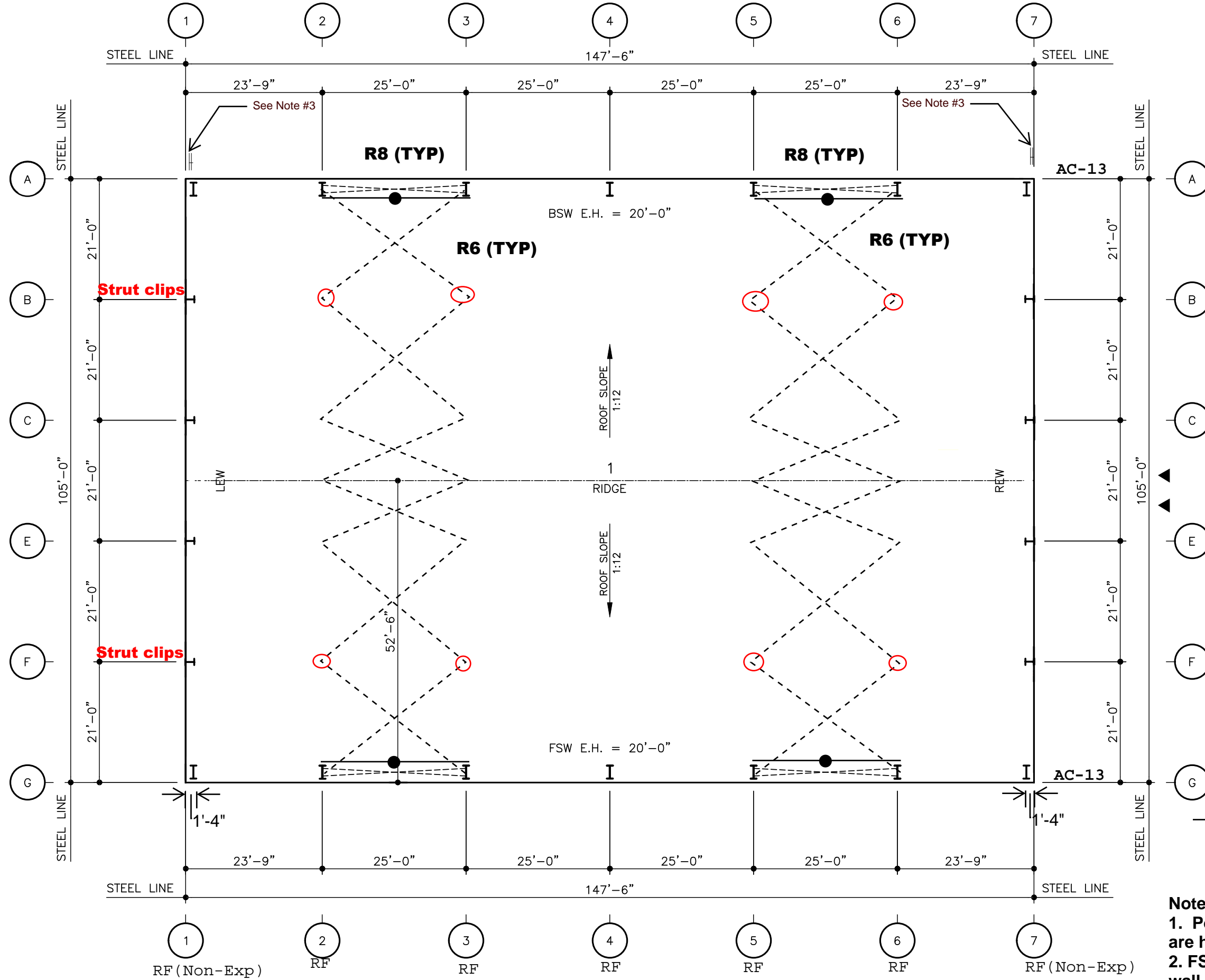

● 12ga Strut 1' uphill  
 ▲ ANTI-ROLL CLIP

**Note:**  
 1. Posts @ 1/B,C,E,F & 7/B,C,E,F are hang posts.  
 2. FSW, LEW, & REW have 8" CMU wall up to 12'.  
 3. Has a 4" seismic gap between the 8" CMU wall and all CBC steel.

STEEL BUILDINGS A TRUSSTECH COMPANY Drawing Generated By eQuote 	
PROJECT NAME: <b>ROB RERTH ICE LAND</b> SACRAMENTO, CA CUSTOMER NAME: <b>R.C. PATTERSON, INC.</b> PENRYN, CA	
DO NOT USE FOR FINAL CONSTRUCTION SHEET TITLE: <b>PRELIMINARY FLOOR PLAN</b>	SHEET NUMBER: <b>FP1</b>
SHEET DATE: 7/7/2022 4:02 PM	QUOTE NUMBER: <b>CB0-220613R1</b>

Project No. : C22B0182A  
 Description : Rob Kerth Ice Land  
 Engineer : VP  
 Date : 8/22/2022

**Wind Loading per ASCE 7-16**  
 with AISI 2016 Specification and 2012 MBMA Manual

Version: 2020.07.27 (Date: 07/27/20) By NBG-GS

**Wall Sheeting Spans**

Building Name: Building A

Wall Panel Selection: Std. R Panel 26 Ga. Grade 80, with Fy = 80ksi Fu = 82ksi

Deflection Limit: L/60

**a = 8.00 ft.**

Min. Girt Thickness for Fastener Checks: 0.060

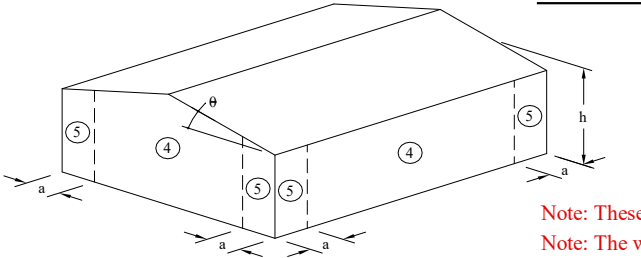

Item	Tributary Area (ft <sup>2</sup> )	Pressure Zones 4,5 (psf)	Suction Zone 4 (psf)	Suction Zone 5 (psf)
Wall Panel	12	15.21	-16.49	-20.16
Simple Span (ft) →		7.95	8.00	7.47
2 Equal Spans (ft) →		8.00	7.63	6.86
3 Equal Spans (ft) →		8.00	8.00	7.47
Fasteners (ft) →		---	7.50	7.50

Note: These panel spans are based on values found in the EDM per brand

Note: The wind loads determined in this sheet are multiplied by 0.6

Note: 50 Year-Wind deflection check

**Roof Sheeting Spans**

Self Weight (psf): 0.97 Collateral Load (psf): 0.00 Max Live/Snow Load (psf): 20.00

Roof Panel Selection: Std. R Panel 26 Ga. Grade 80, with Fy = 80ksi, Fu=82ksi

Deflection Limit: L/60

Minimum Purlin Thickness for Fastener: 0.060

Seaming Option for Interior Zone, (Zone 1): N/A

Seaming Option for Edge Zone, (Zone 2): N/A

Seaming Option for Corner Zone, (Zone 3): N/A

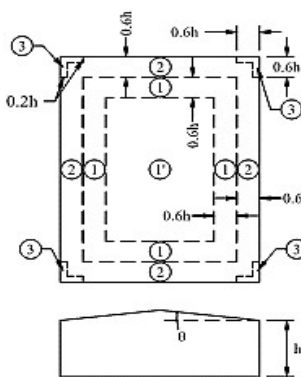

**0.6h = 12.00 ft.**

**0.2h = 4.00 ft.**

Item	Pressure All (ft.)	Suction in Zones				
		1' (ft.)	1 (ft.)	2 (ft.)	3 (ft.)	---
Roof Panel, (psf) →	23.17	-14.81	-26.20	-34.75	-47.58	----
Simple Span	5.50	5.50	5.50	5.50	4.84	
2 Equal Spans	5.50	5.50	5.50	5.27	4.48	
3 Equal Spans	5.50	5.50	5.50	5.50	4.84	
Seaming / Fasteners		6.00	6.00	6.00	4.58	

Note: These Panel Spans are Based on Values Found In the EDM for each brand

Note: The wind loads determined in this sheet are multiplied by 0.6

Note: 50 Year-Wind deflection check



**CHART - 'C'**  
**('R'-Panel)**

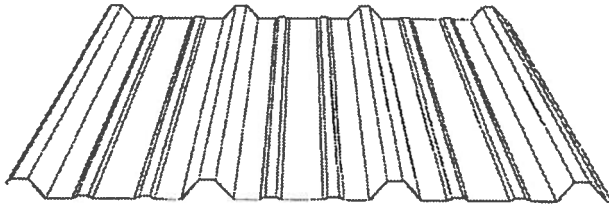

**R-Panel Profile**

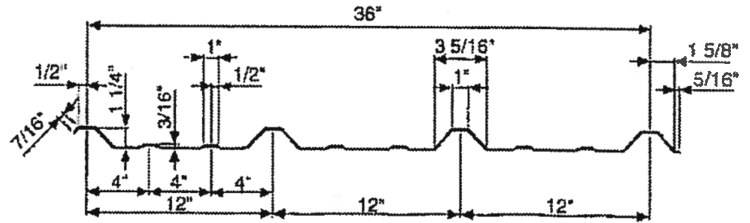

**R-Panel Cross Section**

Standard R-Panel Engineering Properties							
Gauge	Design Thickness	Total Thickness	Panel Weight	Top in Compression		Bottom in Compression	
	IN	IN		Ix	Sx	Ix	Sx
26	0.0177	0.0199	0.97	0.0397	0.0398	0.0317	0.0471
24	0.0225	0.0244	1.19	0.0543	0.0551	0.0423	0.0607

**R Panel SAFE UNIFORM LOAD (PSF)**  
**GRAVITY (PRESSURE)**

TYPE OF SPAN	GAUGE	SPAN (FT)												
		2	2.5	3	3.5	4	4.5	5	5.5	6	6.5	7	7.3333	8
SIMPLE SPAN	26	238	152	106	78	60	47	38	32	26	23	19	18	15
	80 ksi	430	220	127	80	54	38	28	21	16	13	10	9	7
	26	211	135	94	69	53	42	34	28	23	20	17	16	13
	50 ksi	433	222	128	81	54	38	28	21	16	13	10	9	7
	24	294	188	131	96	73	58	47	39	33	28	24	22	18
TWO SPAN	50 ksi	619	317	183	116	77	54	40	30	23	18	14	13	10
	26	277	177	123	90	69	55	44	37	31	26	23	21	17
	80 ksi	1035	530	307	193	129	91	66	50	38	30	24	21	16
	26	233	149	104	76	58	46	37	31	26	22	19	17	15
	50 ksi	1044	535	309	195	130	92	67	50	39	30	24	21	16
THREE OR MORE SPANS	24	299	192	133	98	75	59	48	40	33	28	24	22	19
	50 ksi	1491	764	442	278	186	131	95	72	55	43	35	30	23
	26	323	207	144	106	81	64	52	43	36	31	26	24	20
	80 ksi	861	441	255	161	108	76	55	41	32	25	20	17	13
	26	272	174	121	89	68	54	44	36	30	26	22	20	17
THREE OR MORE SPANS	50 ksi	868	445	257	162	109	76	56	42	32	25	20	18	14
	24	349	224	155	114	87	69	56	46	39	33	29	26	22
	50 ksi	1240	635	367	231	155	109	79	60	46	36	29	25	19

**UPLIFT (SUCTION)**

TYPE OF SPAN	GAUGE	SPAN (FT)												
		2	2.5	3	3.5	4	4.5	5	5.5	6	6.5	7	7.3333	8
SIMPLE SPAN	26	277	177	123	90	69	55	44	37	31	26	23	21	17
	80 ksi	350	179	104	65	44	31	22	17	13	10	8	7	5
	26	233	149	104	76	58	46	37	31	26	22	19	17	15
	50 ksi	361	185	107	67	45	32	23	17	13	11	8	7	6
	24	299	192	133	98	75	59	48	40	33	28	24	22	19
TWO SPAN	50 ksi	481	246	142	90	60	42	31	23	18	14	11	10	8
	26	238	152	106	78	60	47	38	32	26	23	19	18	15
	80 ksi	842	431	250	157	105	74	54	40	31	25	20	17	13
	26	211	135	94	69	53	42	34	28	23	20	17	16	13
	50 ksi	869	445	257	162	109	76	56	42	32	25	20	18	14
THREE OR MORE SPANS	24	294	188	131	96	73	58	47	39	33	28	24	22	18
	50 ksi	1158	593	343	216	145	102	74	56	43	34	27	23	18
	26	278	178	124	91	70	55	44	37	31	26	23	21	17
	80 ksi	700	359	208	131	88	61	45	34	26	20	16	14	11
	26	246	158	109	80	62	49	39	33	27	23	20	18	15
THREE OR MORE SPANS	50 ksi	722	370	214	135	90	63	46	35	27	21	17	15	11
	24	343	220	152	112	88	68	55	45	38	32	28	26	21
	50 ksi	963	493	285	180	120	85	62	46	36	28	22	20	15

- Notes:
- E = 29500
  - Top value is based on stress and bottom value is based on deflection.
  - Weight of panel is not included in the above allowables.
  - Deflection allowables are based on l/180. To adjust for other limits use the following:  
For l/90 multiply the above allowables by 2.0  
For l/240 multiply the above allowables by 0.75
  - Stress allowables may be increased by 4/3 for wind loading if allowed by the building code.
  - The panel properties are calculated in accordance with the 2012 North American Specification for the Design of Cold Formed Steel Structural Members.

NBG LIGHT GAGE ANALYSIS SHORT REPORT | 08/24/2022

Software: NBG Light Gage Analysis [version: 2018.12.04.1 date: 12/04/2018]  
 Analysis Config: CBC [version: 2016.07.12.001]

Input File: C:\Users\viviana.perez\OneDrive - Nucor\Desktop\Vivi's Projects\Current\182 Rob Kerth Ice Land\Light Gage\Purlin\Rob Kerth Ice land purlins

Project Name: Rob Kerth Ice land purlins

AISI Spec Year: 2016  
 Building Code: IBC 2018  
 Inventory: CBCCA-RP

See D-11

Purlin spacing: 5.00 o.c.  
 Insulation Thickness: 0.00

SPAN PARAMETERS

Span	Length	Section	Design Group	Design	Brace Type	Left Support	Right Support	Left Lap	Right Lap
	(ft)							(in)	(in)
1	1.33	08Z089	1	No	Top	1	2	Cant.	0.00
2	22.42	08Z089	1	No	Top	2	3	0.00	46.50
3	25.00	08Z067	2	No	Top	3	4	46.50	30.50
4	25.00	08Z067	3	No	Top	4	5	30.50	30.50
5	25.00	08Z067	4	No	Top	5	6	30.50	30.50
6	25.00	08Z067	5	No	Top	6	7	30.50	46.50
7	22.42	08Z089	6	No	Top	7	8	46.50	0.00
8	1.33	08Z089	6	No	Top	8	9	0.00	Cant.

MAXIMUM COMPUTED DISPLACEMENTS, FORCES & LOAD RATIOS

Span Properties			Maximum Computed Displacements & Forces						Maximum Computed Load Ratios					
No	Length	Section	Displacement	Axial	Shear	Moment(+)	Moment(-)	Ten.(T)	Comp.(P)	Shear(V)	Mom.(M)	T&M	P&M	V&M
1	1.33	08Z089	0.215	0.00	0.20	0.11	-0.13	0.00	0.00	0.02	0.02	0.02	0.02	0.03
		x	0.00	0.00	16.00	16.00	16.00	0.00	0.00	16.00	16.00	16.00	16.00	16.00
		comb	12	0	12	4	12	0	0	2	12	12	12	2
2	22.42	08Z089	-0.942	1.66	2.09	6.30	-9.73	0.00	0.15	0.18	0.73	0.73	0.91	0.75
		x	117.11	245.75	269.00	269.00	269.00	0.00	0.00	222.50	269.00	269.00	93.68	269.00
		comb	12	4	12	4	12	0	4	12	12	12	4	12
3	25.00	08Z067	-0.513	3.58	1.92	6.30	-9.73	0.00	0.45	0.39	0.84	0.84	0.88	0.81
		x	150.00	269.50	0.00	0.00	0.00	0.00	46.50	269.50	269.50	269.50	46.50	269.50
		comb	12	10	12	4	12	0	10	12	12	12	4	12
4	25.00	08Z067	-0.764	0.67	1.88	5.24	-8.57	0.00	0.09	0.41	0.93	0.93	0.93	0.89
		x	150.00	289.83	300.00	300.00	300.00	0.00	30.50	269.50	269.50	269.50	269.50	269.50
		comb	12	4	12	4	12	0	4	12	12	12	12	12
5	25.00	08Z067	-0.764	0.67	1.88	5.24	-8.57	0.00	0.09	0.41	0.93	0.93	0.93	0.89
		x	150.00	269.50	0.00	0.00	0.00	0.00	30.50	30.50	30.50	30.50	30.50	30.50
		comb	12	4	12	4	12	0	4	12	12	12	12	12
6	25.00	08Z067	-0.514	3.58	1.92	6.29	-9.73	0.00	0.45	0.39	0.84	0.84	0.88	0.81
		x	138.50	265.12	300.00	300.00	300.00	0.00	30.50	30.50	30.50	30.50	253.50	30.50
		comb	12	10	12	4	12	0	10	12	12	12	4	12
7	22.42	08Z089	-0.942	1.66	2.09	6.29	-9.73	0.00	0.15	0.18	0.73	0.73	0.90	0.75
		x	151.89	58.21	0.00	0.00	0.00	0.00	46.50	46.50	0.00	0.00	163.61	0.00
		comb	12	4	12	4	12	0	4	12	12	12	4	12
8	1.33	08Z089	0.215	0.00	0.20	0.11	-0.13	0.00	0.00	0.02	0.02	0.02	0.02	0.03
		x	16.00	0.00	0.00	0.00	0.00	0.00	0.00	0.00	0.00	0.00	0.00	0.00
		comb	12	0	12	4	12	0	0	2	12	12	12	2
			Displacement	Axial	Shear	Moment(+)	Moment(-)	Ten.(T)	Comp.(P)	Shear(V)	Mom.(M)	T&M	P&M	V&M
Max of All Spans			-0.942	3.58	2.09	6.30	-9.73	0.00	0.45	0.41	0.93	0.93	0.93	0.89
Distance from Left			117.11	269.50	269.00	269.00	269.00	0.00	46.50	269.50	269.50	269.50	269.50	269.50
Span			2	3	2	2	2	0	3	4	4	4	4	4
Load Combination			12	10	12	4	12	0	10	12	12	12	12	12

SUPPORT CONNECTIONS

Support No.	2	3	4	5	6	7	8
Connection Code	NC	NC	NC	NC	NC	NC	NC

\* Roofing is screwed down

VERTICAL REACTIONS [kips]

Comb	Support No
------	------------

	1	2	3	4	5	6	7	8	9
1	0.00	-0.96	-2.69	-2.41	-2.52	-2.41	-2.69	-0.96	0.00
2	0.00	-1.32	-3.70	-3.32	-3.47	-3.32	-3.70	-1.32	0.00
3	0.00	-0.36	-1.01	-0.91	-0.95	-0.91	-1.01	-0.36	0.00
4	0.00	1.14	2.54	2.13	2.28	2.13	2.53	1.14	0.00
5	0.00	0.78	1.71	1.44	1.54	1.44	1.71	0.78	0.00
6	0.00	0.86	1.73	1.41	1.52	1.41	1.72	0.85	0.00
7	0.00	0.55	1.04	0.83	0.90	0.83	1.04	0.55	0.00
8	0.00	-0.17	-0.98	-0.98	-0.99	-0.98	-0.98	-0.17	0.00
9	0.00	-0.71	-1.99	-1.79	-1.86	-1.79	-1.99	-0.71	0.00
10	0.00	-0.06	-0.18	-0.16	-0.17	-0.16	-0.18	-0.06	0.00
11	0.00	-0.39	-1.08	-0.97	-1.02	-0.97	-1.08	-0.39	0.00
12	0.00	-1.43	-4.01	-3.60	-3.75	-3.60	-4.01	-1.43	0.00

\* Negative reaction for gravity loads

SUPPORT RATIOS

Support	Support Type*		Crippling	Crip & Bend	Bolt Shear	Bearing*
2	3	Max Ratios Combo	0.36 12	0.27 12	0.27 12	0.19 12
3	3	Max Ratios Combo	0.66 12	0.81 12	0.76 12	0.31 12
4	3	Max Ratios Combo	0.84 12	0.90 12	0.68 12	0.32 12
5	3	Max Ratios Combo	0.88 12	0.96 12	0.71 12	0.33 12
6	3	Max Ratios Combo	0.84 12	0.90 12	0.68 12	0.32 12
7	3	Max Ratios Combo	0.66 12	0.81 12	0.76 12	0.31 12
8	3	Max Ratios Combo	0.36 12	0.27 12	0.27 12	0.19 12
Maximum Ratios of All Supports			0.88	0.96	0.76	0.33
Support			5	5	3	5
Combo			12	12	12	12
Support Type			3	3	3	3

\* Bolt type between purlin & clip: A307

\* Support types: 1 = No Clip | 2 = Crippling Clip | 3 = Bolted or Welded Clip w/ A307 | 4 = Bolted or Welded Clip w/ A325

\* Bearing ratio is check of bearing of clip bolts on purlins

GENERAL LOADS

Load Case	Uniform Load (psf)	Load Case Name
1	2.5	Dead Load
2	5.0	Collateral Load
3	0.0	Snow Load
4	20.0	Live Load
5	-32.2	Wind Load
6	-42.9	Edge Zone Wind Load
7	0.0	Alternate Snow Load
8	16.0	Wind Pressure Load
9	1.0	Seismic Load

LINEAR LOADS

Load Case	Span	Load Type	Start Load (lb/ft)	Start X (ft)	End Load (lb/ft)	End X (ft)
1	1	Shear	12.50	0.00	12.50	1.33
1	2	Shear	12.50	0.00	12.50	22.42
1	3	Shear	12.50	0.00	12.50	25.00
1	4	Shear	12.50	0.00	12.50	25.00
1	5	Shear	12.50	0.00	12.50	25.00
1	6	Shear	12.50	0.00	12.50	25.00
1	7	Shear	12.50	0.00	12.50	22.42
1	8	Shear	12.50	0.00	12.50	1.33
2	1	Shear	24.90	0.00	24.90	1.33
2	2	Shear	24.90	0.00	24.90	22.42
2	3	Shear	24.90	0.00	24.90	25.00
2	4	Shear	24.90	0.00	24.90	25.00
2	5	Shear	24.90	0.00	24.90	25.00
2	6	Shear	24.90	0.00	24.90	25.00
2	7	Shear	24.90	0.00	24.90	22.42
2	8	Shear	24.90	0.00	24.90	1.33
4	1	Shear	99.30	0.00	99.30	1.33
4	2	Shear	99.30	0.00	99.30	22.42
4	3	Shear	99.30	0.00	99.30	25.00
4	4	Shear	99.30	0.00	99.30	25.00
4	5	Shear	99.30	0.00	99.30	25.00
4	6	Shear	99.30	0.00	99.30	25.00
4	7	Shear	99.30	0.00	99.30	22.42
4	8	Shear	99.30	0.00	99.30	1.33
5	1	Shear	-214.30	0.00	-214.30	1.33
5	2	Shear	-214.30	0.00	-214.30	10.67
5	2	Shear	-160.90	10.67	-160.90	22.42
5	3	Shear	-160.90	0.00	-160.90	25.00

5	4	Shear	-160.90	0.00	-160.90	25.00
5	5	Shear	-160.90	0.00	-160.90	25.00
5	6	Shear	-160.90	0.00	-160.90	25.00
5	7	Shear	-160.90	0.00	-160.90	11.75
5	7	Shear	-214.30	11.75	-214.30	22.42
5	8	Shear	-214.30	0.00	-214.30	1.33
8	1	Shear	80.00	0.00	80.00	1.33
8	2	Shear	80.00	0.00	80.00	22.42
8	3	Shear	80.00	0.00	80.00	25.00
8	4	Shear	80.00	0.00	80.00	25.00
8	5	Shear	80.00	0.00	80.00	25.00
8	6	Shear	80.00	0.00	80.00	25.00
8	7	Shear	80.00	0.00	80.00	22.42
8	8	Shear	80.00	0.00	80.00	1.33

CONCENTRATED LOADS

Load Case	Span	P (k)	V (k)	M (k-ft)	X (ft)
5	2	2.76	0.00	0.00	0.00
5	2	-2.76	0.00	0.00	22.42
5	3	4.57	0.00	0.00	0.00
5	3	-4.57	0.00	0.00	25.00
5	4	1.12	0.00	0.00	0.00
5	4	-1.12	0.00	0.00	25.00
5	5	1.12	0.00	0.00	0.00
5	5	-1.12	0.00	0.00	25.00
5	6	4.57	0.00	0.00	0.00
5	6	-4.57	0.00	0.00	25.00
5	7	2.76	0.00	0.00	0.00
5	7	-2.76	0.00	0.00	22.42
9	2	0.39	0.00	0.00	0.00
9	2	-0.39	0.00	0.00	22.42
9	3	3.93	0.00	0.00	0.00
9	3	-3.93	0.00	0.00	25.00
9	4	0.44	0.00	0.00	0.00
9	4	-0.44	0.00	0.00	25.00
9	5	0.44	0.00	0.00	0.00
9	5	-0.44	0.00	0.00	25.00
9	6	3.93	0.00	0.00	0.00
9	6	-3.93	0.00	0.00	25.00
9	7	0.39	0.00	0.00	0.00
9	7	-0.39	0.00	0.00	22.42

LOAD COMBINATIONS

Comb #	Active (Y/N)	Load Combination Name	Allowable Factor	Load Case No.									
				1	2	3	4	5	6	7	8	9	
1	Y	Live Load Only	1.00	0.00	0.00	0.00	1.00	0.00	0.00	0.00	0.00	0.00	0.00
2	Y	DL + COL + LL	1.00	1.00	1.00	0.00	1.00	0.00	0.00	0.00	0.00	0.00	0.00
3	Y	DL + COL + SL	1.00	1.00	1.00	1.00	0.00	0.00	0.00	0.00	0.00	0.00	0.00
4	Y	0.6 DL + 0.6 WL	1.00	0.60	0.00	0.00	0.00	0.60	0.00	0.00	0.00	0.00	0.00
5	Y	0.6 DL + 0.42 WL	1.00	0.60	0.00	0.00	0.00	0.42	0.00	0.00	0.00	0.00	0.00
6	Y	DL + COL + 0.6 WL	1.00	1.00	1.00	0.00	0.00	0.60	0.00	0.00	0.00	0.00	0.00
7	Y	DL + COL + 0.75 SL + 0.45 WL	1.00	1.00	1.00	0.75	0.00	0.45	0.00	0.00	0.00	0.00	0.00
8	Y	DL + COL + 0.75 LL + 0.45 WL	1.00	1.00	1.00	0.00	0.75	0.45	0.00	0.00	0.00	0.00	0.00
9	Y	DL + COL + 0.75 SL + 0.45 WP	1.00	1.00	1.00	0.75	0.00	0.00	0.00	0.00	0.45	0.00	0.00
10	Y	0.53DL+0.91E	1.00	0.53	0.00	0.00	0.00	0.00	0.00	0.00	0.00	0.00	0.91
11	Y	1.07DL+1.07COL+0.91E	1.00	1.07	1.07	0.00	0.00	0.00	0.00	0.00	0.00	0.00	0.91
12	Y	DL+COL+0.75LL+0.45WPL	1.00	1.00	1.00	0.00	0.75	0.00	0.00	0.00	0.00	0.45	0.00

DEFLECTION LIMITATIONS

The deflection limit with DEAD LOAD = L / 120.0  
 The maximum deflection with DEAD LOAD = 2.50"  
 The deflection limit without DEAD LOAD = L / 150.0  
 The maximum deflection without DEAD LOAD = 2.00"

\* Deflection limitations were applied to combinations 1-3,5

GENERAL NOTES

\* '\* Ends of laps are considered as brace points.'  
 \* '\* Inflection points are considered brace points except for spans with discrete bracing.'  
 \* All calculations are in accordance with the 2016 North American Specification.

SYSTEM WEIGHT & COST

Total system weight = 630.20 lbs  
 Total system cost = 1109.95 dollars

PURLIN PRODUCTION LIST

Purlin	Section	Length
1	08Z089	27.62
2	08Z067	31.42
3	08Z067	30.08
4	08Z067	30.08
5	08Z067	31.42
6	08Z089	27.62

MATERIAL SUMMARY



Section	Weight	Cost	Fy
08Z067	394.83	705.55	55.0
08Z089	235.37	404.41	55.0



1	0.00	-0.83	-2.27	-2.07	-2.13	-2.07	-2.27	-0.83	0.00
2	0.00	0.95	2.51	2.27	2.35	2.27	2.51	0.95	0.00
3	0.00	-0.58	-1.59	-1.45	-1.49	-1.45	-1.59	-0.58	0.00
4	0.00	0.67	1.75	1.59	1.65	1.59	1.75	0.67	0.00

\* Negative reaction for gravity loads

SUPPORT RATIOS

Support	Support Type*		Crippling	Crip & Bend	Bolt Shear	Bearing*
2	1	Max Ratios Combo	0.49 1	0.36 1	0.18 2	0.19 2
3	1	Max Ratios Combo	0.68 1	0.70 1	0.47 2	0.25 2
4	1	Max Ratios Combo	0.62 1	0.62 1	0.43 2	0.23 2
5	1	Max Ratios Combo	0.64 1	0.65 1	0.44 2	0.23 2
6	1	Max Ratios Combo	0.62 1	0.62 1	0.43 2	0.23 2
7	1	Max Ratios Combo	0.68 1	0.70 1	0.47 2	0.25 2
8	1	Max Ratios Combo	0.49 1	0.36 1	0.18 2	0.19 2
Maximum Ratios of All Supports			0.68	0.70	0.47	0.25
Support			3	3	7	7
Combo			1	1	2	2
Support Type			1	1	1	1

\* Bolt type between purlin & clip: A307

\* Support types: 1 = No Clip | 2 = Crippling Clip | 3 = Bolted or Welded Clip w/ A307 | 4 = Bolted or Welded Clip w/ A325

\* Bearing ratio is check of bearing of clip bolts on purlins

GENERAL LOADS

Load Case	Uniform Load (psf)	Load Case Name
1	20.8	Pressure Wind Load
2	-23.0	Suction Wind Load
3	-24.6	Edge Suction Wind Load

LINEAR LOADS

Load Case	Span	Load Type	Start Load (lb/ft)	Start X (ft)	End Load (lb/ft)	End X (ft)
1	1	Shear	140.70	0.00	140.70	1.33
1	2	Shear	140.70	0.00	140.70	22.42
1	3	Shear	140.70	0.00	140.70	25.00
1	4	Shear	140.70	0.00	140.70	25.00
1	5	Shear	140.70	0.00	140.70	25.00
1	6	Shear	140.70	0.00	140.70	25.00
1	7	Shear	140.70	0.00	140.70	22.42
1	8	Shear	140.70	0.00	140.70	1.33
2	1	Shear	-165.90	0.00	-165.90	1.33
2	2	Shear	-165.90	0.00	-165.90	6.67
2	2	Shear	-155.00	6.67	-155.00	22.42
2	3	Shear	-155.00	0.00	-155.00	25.00
2	4	Shear	-155.00	0.00	-155.00	25.00
2	5	Shear	-155.00	0.00	-155.00	25.00
2	6	Shear	-155.00	0.00	-155.00	25.00
2	7	Shear	-155.00	0.00	-155.00	15.75
2	7	Shear	-165.90	15.75	-165.90	22.42
2	8	Shear	-165.90	0.00	-165.90	1.33

LOAD COMBINATIONS

Comb	Active	Load Combination Name	Allowable Factor	Load Case No.	
#	(Y/N)			1	2
1	Y	Wind Pressure	1.00	0.60	0.00
2	Y	Wind Suction	1.00	0.00	0.60
3	Y	Wind Pressure Deflection	1.00	0.42	0.00
4	Y	Wind Suction Deflection	1.00	0.00	0.42

DEFLECTION LIMITATIONS

The 50 year deflection limit = L / 90.0  
 The 50 year maximum deflection = 3.33"

\* Deflection limitations were applied to combinations 3-4

GENERAL NOTES

\* '\* Ends of laps are considered as brace points.'  
\* '\* Inflection points are considered brace points except for spans with discrete bracing.'  
\* All calculations are in accordance with the 2016 North American Specification.

SYSTEM WEIGHT & COST

=====  
Total system weight = 477.14 lbs  
Total system cost = 862.21 dollars

PURLIN PRODUCTION LIST

=====  
-----  
-----

Purlin	Section	Length
1	08Z060	25.62
2	08Z060	28.75
3	08Z060	28.75
4	08Z060	28.75
5	08Z060	28.75
6	08Z060	25.62

-----  
-----

MATERIAL SUMMARY

=====  
-----  
-----

Section	Weight	Cost	Fy
08Z060	477.14	862.21	55.0

-----  
-----

NBG LIGHT GAGE ANALYSIS SHORT REPORT | 08/23/2022

Software: NBG Light Gage Analysis [version: 2018.12.04.1 date: 12/04/2018]  
 Analysis Config: CBC [version: 2016.07.12.001]  
 Input File: C:\Users\viviana.perez\OneDrive - Nucor\Desktop\Vivi's Projects\Current\182 Rob Kerth Ice Land\Light Gage\EW\Ice land EW  
 Project Name: Ice land EW  
 AISI Spec Year: 2016  
 Building Code: IBC 2018  
 Inventory: CBCCA-RP

See D-14,15

Girts @13'-6", 17'-6", 22'-6"

Purlin spacing: 5.00 o.c.  
 Insulation Thickness: 0.00

SPAN PARAMETERS

Span	Length	Section	Design Group	Design	Brace Type	Left Support	Right Support	Left Lap	Right Lap
	(ft)							(in)	(in)
1	21.00	08Z075	1	Yes	Top	1	2	----	0.00
2	21.00	08Z075	2	Yes	Top	2	3	0.00	0.00
3	21.00	08Z075	3	Yes	Top	3	4	0.00	0.00
4	21.00	08Z075	4	Yes	Top	4	5	0.00	0.00
5	21.00	08Z075	5	Yes	Top	5	6	0.00	----

MAXIMUM COMPUTED DISPLACEMENTS, FORCES & LOAD RATIOS

Span Properties			Maximum Computed Displacements & Forces							Maximum Computed Load Ratios				
No	Length	Section	Displacement	Axial	Shear	Moment(+)	Moment(-)	Ten.(T)	Comp.(P)	Shear(V)	Mom.(M)	T&M	P&M	V&M
1	21.00	08Z075	1.058	0.00	-0.78	3.50	-3.96	0.00	0.00	0.15	0.97	0.97	0.97	0.63
		x	120.00	0.00	0.00	132.00	120.00	0.00	0.00	0.00	120.00	120.00	120.00	120.00
		comb	2	0	2	1	2	0	0	2	2	2	2	2
2	21.00	08Z075	1.030	0.00	-0.74	3.50	-3.86	0.00	0.00	0.14	0.95	0.95	0.95	0.61
		x	120.00	0.00	0.00	132.00	120.00	0.00	0.00	0.00	120.00	120.00	120.00	120.00
		comb	2	0	2	1	2	0	0	2	2	2	2	2
3	21.00	08Z075	1.030	0.00	-0.74	3.50	-3.86	0.00	0.00	0.14	0.95	0.95	0.95	0.61
		x	120.00	0.00	0.00	132.00	120.00	0.00	0.00	0.00	120.00	120.00	120.00	120.00
		comb	2	0	2	1	2	0	0	2	2	2	2	2
4	21.00	08Z075	1.030	0.00	-0.74	3.50	-3.86	0.00	0.00	0.14	0.95	0.95	0.95	0.61
		x	120.00	0.00	0.00	132.00	120.00	0.00	0.00	0.00	120.00	120.00	120.00	120.00
		comb	2	0	2	1	2	0	0	2	2	2	2	2
5	21.00	08Z075	1.058	0.00	-0.78	3.50	-3.96	0.00	0.00	0.15	0.97	0.97	0.97	0.63
		x	132.00	0.00	252.00	132.00	132.00	0.00	0.00	252.00	120.00	120.00	120.00	120.00
		comb	2	0	2	1	2	0	0	2	2	2	2	2
			Displacement	Axial	Shear	Moment(+)	Moment(-)	Ten.(T)	Comp.(P)	Shear(V)	Mom.(M)	T&M	P&M	V&M
		Max of All Spans	1.058	0.00	-0.78	3.50	-3.96	0.00	0.00	0.15	0.97	0.97	0.97	0.63
		Distance from Left Span	120.00	0.00	0.00	132.00	120.00	0.00	0.00	0.00	120.00	120.00	120.00	120.00
		1	0	1	1	1	1	0	0	1	1	1	1	1
		Load Combination	2	0	2	1	2	0	0	2	2	2	2	2

SUPPORT CONNECTIONS

Support No.	1	2	3	4	5	6
Connection Code	NC	NC	NC	NC	NC	NC

VERTICAL REACTIONS [kips]

Comb	Support No					
	1	2	3	4	5	6
1	-0.67	-1.34	-1.34	-1.34	-1.34	-0.67
2	0.78	1.48	1.47	1.47	1.48	0.78
3	-0.47	-0.94	-0.94	-0.94	-0.94	-0.47
4	0.54	1.04	1.03	1.03	1.04	0.54

\* Negative reaction for gravity loads

SUPPORT RATIOS

Support	Support Type*	Crippling	Crip & Bend	Bolt Shear	Bearing*
1	1	Max Ratios Combo	0.41 1	0.27 1	0.15 2
					0.12 2

Support	Support Type	Max Ratios Combo	0.82	0.55	0.28	0.24
2	1	Max Ratios Combo	0.82	0.55	0.28	0.24
3	1	Max Ratios Combo	0.82	0.55	0.28	0.12
4	1	Max Ratios Combo	0.82	0.55	0.28	0.12
5	1	Max Ratios Combo	0.82	0.55	0.28	0.12
6	1	Max Ratios Combo	0.41	0.27	0.15	0.12
Maximum Ratios of All Supports			0.82	0.55	0.28	0.24
Support			2	2	2	2
Combo			1	1	2	2
Support Type			1	1	1	1

\* Bolt type between purlin & clip: A307  
 \* Support types: 1 = No Clip | 2 = Crippling Clip | 3 = Bolted or Welded Clip w/ A307 | 4 = Bolted or Welded Clip w/ A325  
 \* Bearing ratio is check of bearing of clip bolts on purlins

GENERAL LOADS

Load Case	Uniform Load (psf)	Load Case Name
1	21.2	Pressure Wind Load
2	-23.4	Suction Wind Load
3	-25.4	Edge Suction Wind Load

LINEAR LOADS

Load Case	Span	Load Type	Start Load (lb/ft)	Start X (ft)	End Load (lb/ft)	End X (ft)
1	1	Shear	106.20	0.00	106.20	21.00
1	2	Shear	106.20	0.00	106.20	21.00
1	3	Shear	106.20	0.00	106.20	21.00
1	4	Shear	106.20	0.00	106.20	21.00
1	5	Shear	106.20	0.00	106.20	21.00
2	1	Shear	-126.90	0.00	-126.90	8.00
2	1	Shear	-116.90	8.00	-116.90	21.00
2	2	Shear	-116.90	0.00	-116.90	21.00
2	3	Shear	-116.90	0.00	-116.90	21.00
2	4	Shear	-116.90	0.00	-116.90	21.00
2	5	Shear	-116.90	0.00	-116.90	13.00
2	5	Shear	-126.90	13.00	-126.90	21.00

LOAD COMBINATIONS

Comb #	Active (Y/N)	Load Combination Name	Allowable Factor	Load Case No.	
				1	2
1	Y	Wind Pressure	1.00	0.60	0.00
2	Y	Wind Suction	1.00	0.00	0.60
3	Y	Wind Pressure Deflection	1.00	0.42	0.00
4	Y	Wind Suction Deflection	1.00	0.00	0.42

DEFLECTION LIMITATIONS

The 50 year deflection limit = L / 90.0  
 The 50 year maximum deflection = 2.80"

\* Deflection limitations were applied to combinations 3-4

GENERAL NOTES

\* '\* Ends of laps are considered as brace points.'  
 \* '\* Inflection points are considered brace points except for spans with discrete bracing.'  
 \* All calculations are in accordance with the 2016 North American Specification.

SYSTEM WEIGHT & COST

Total system weight = 376.95 lbs  
 Total system cost = 666.89 dollars

PURLIN PRODUCTION LIST

Purlin	Section	Length
1	08Z075	21.00
2	08Z075	21.00
3	08Z075	21.00
4	08Z075	21.00
5	08Z075	21.00

MATERIAL SUMMARY

Section	Weight	Cost	Fy
08Z075	376.95	666.89	55.0

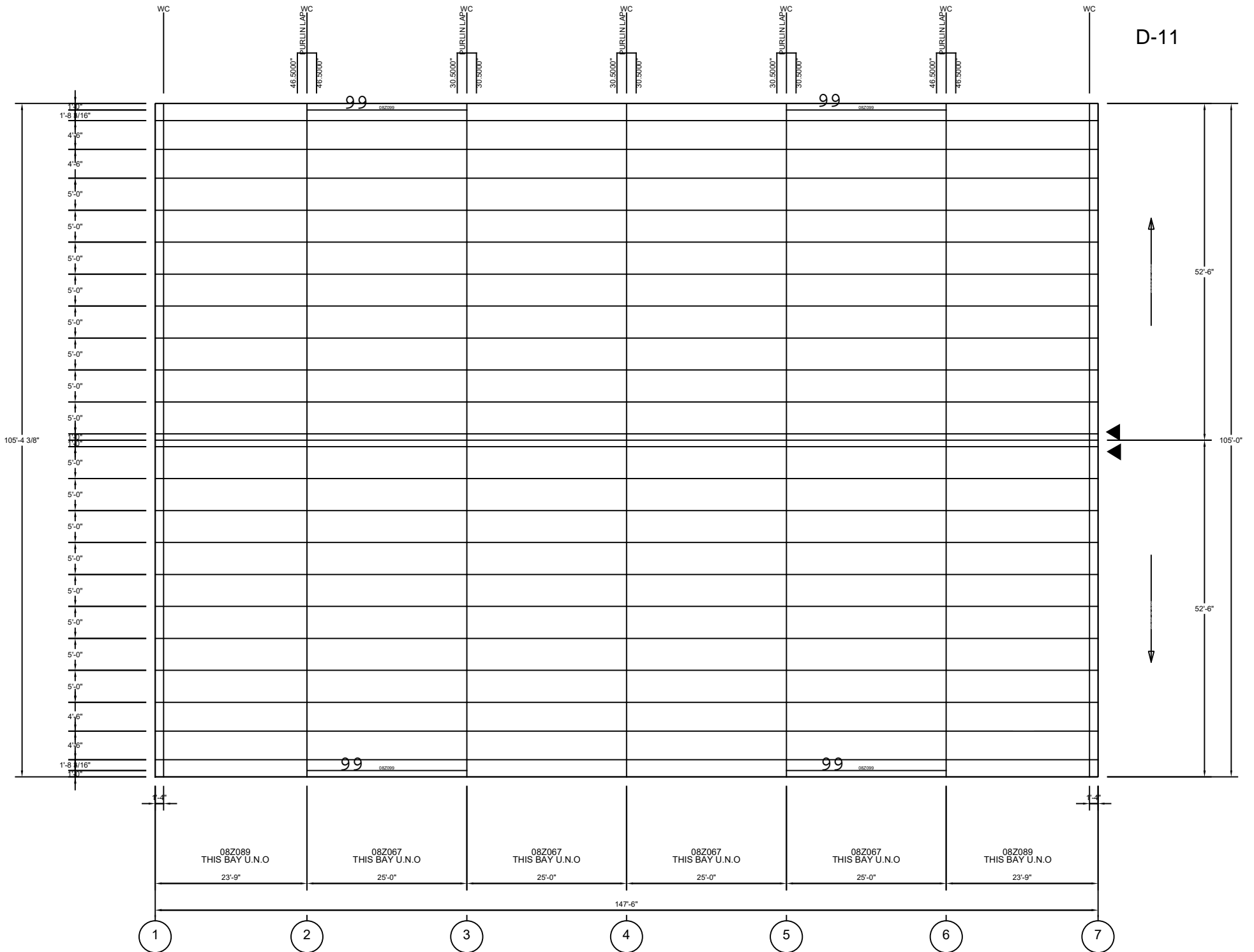

ROOF FRAMING PLAN, FSW: R01 - 1 / BSW: R02 - 1

◀ ANTI-ROLL CLIP



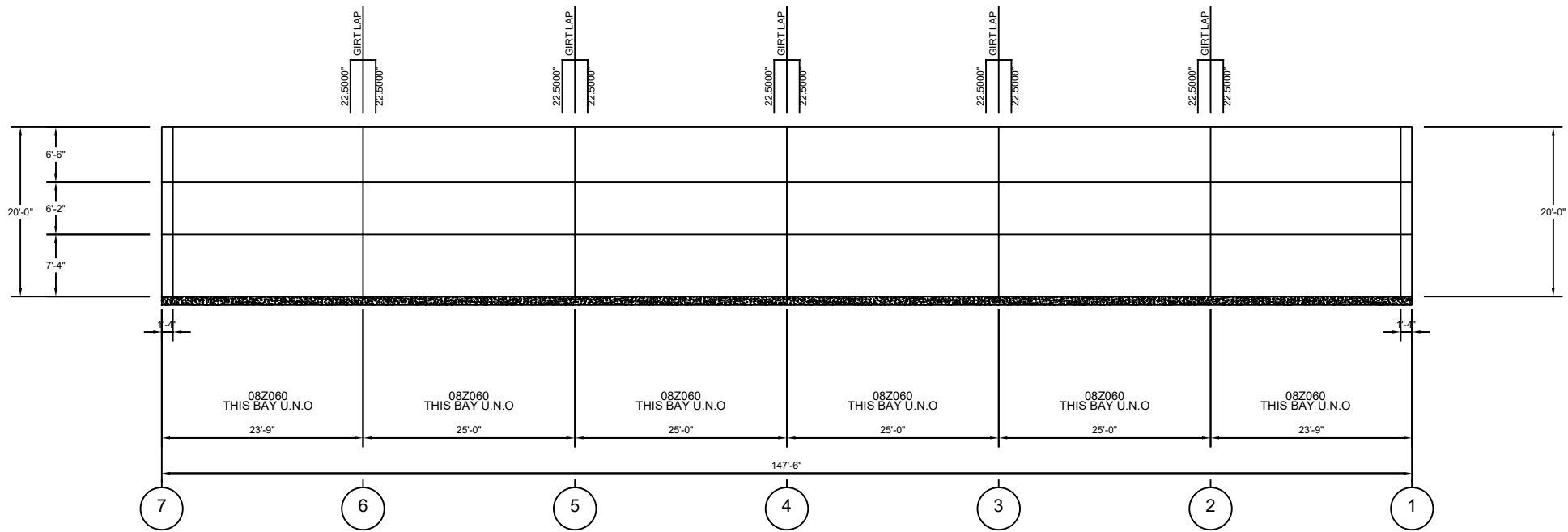

WALL ELEVATION, BSW - 1

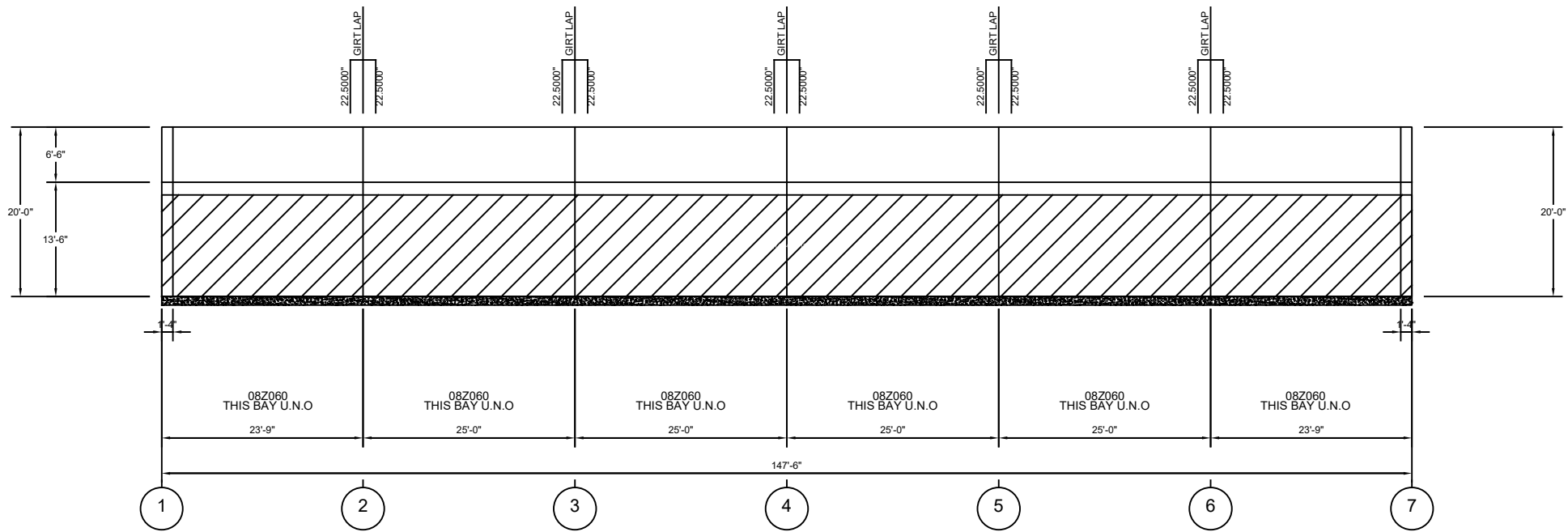

WALL ELEVATION, FSW - 1

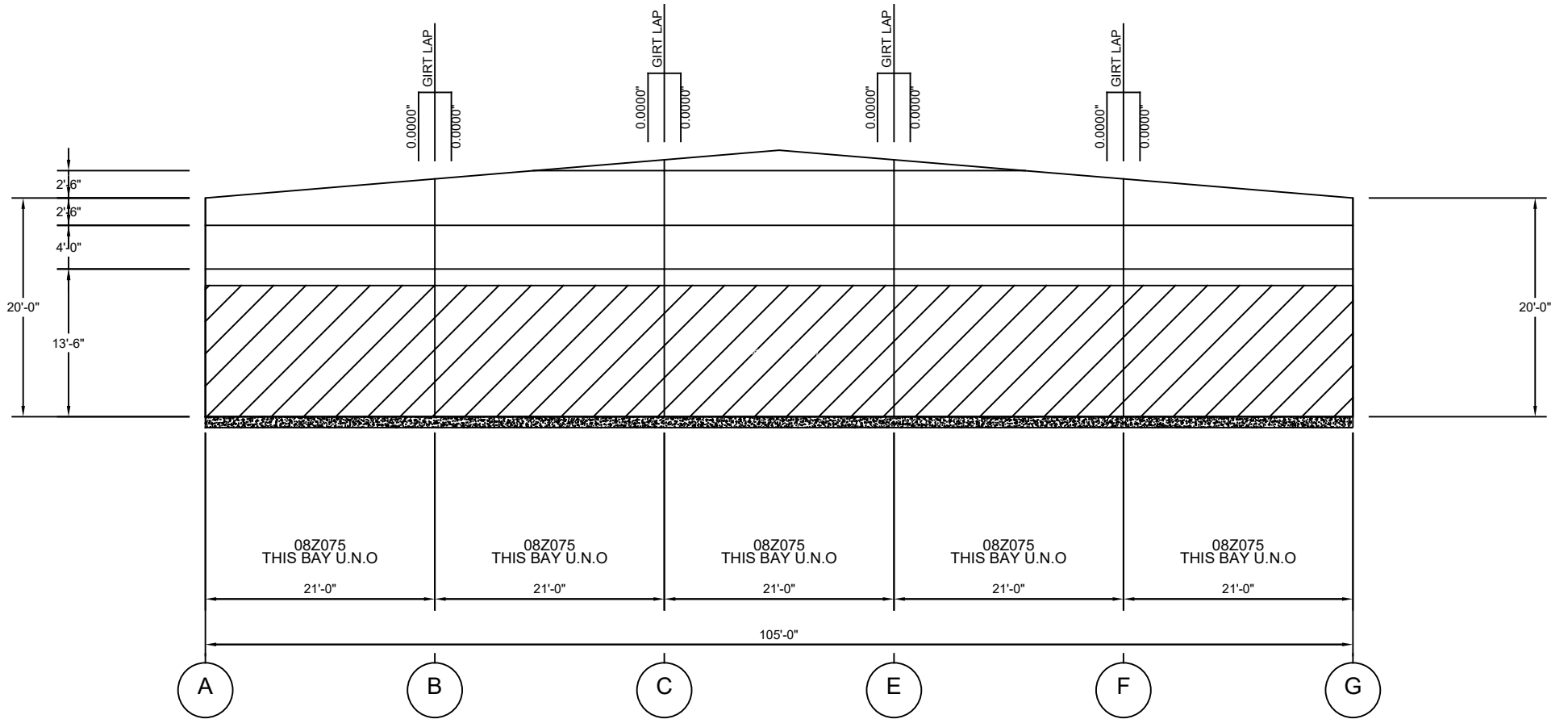

WALL ELEVATION, LEW - 1

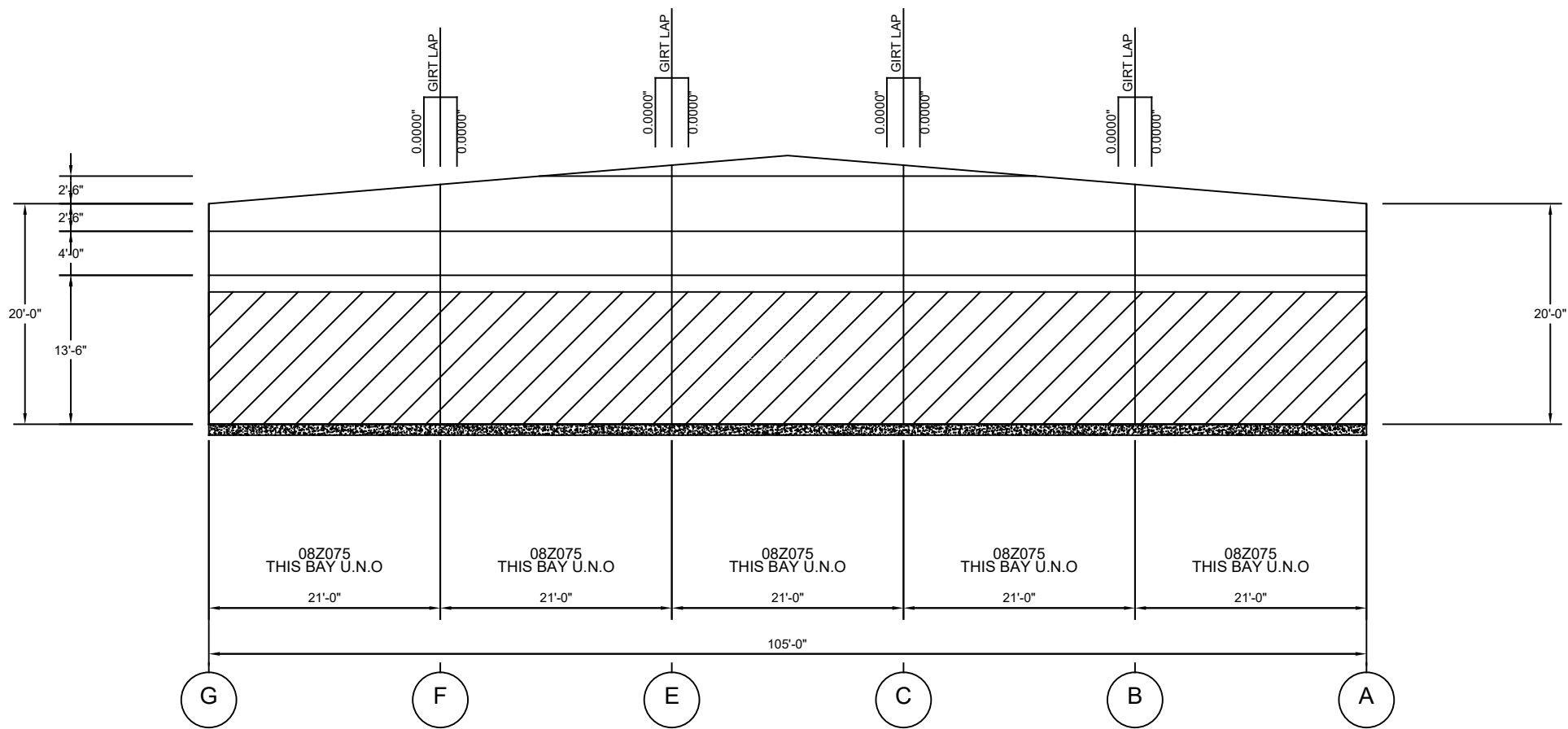

WALL ELEVATION, REW - 1



**8" & 9.5" COLD-FORMED MEMBER SECTION PROPERTIES**

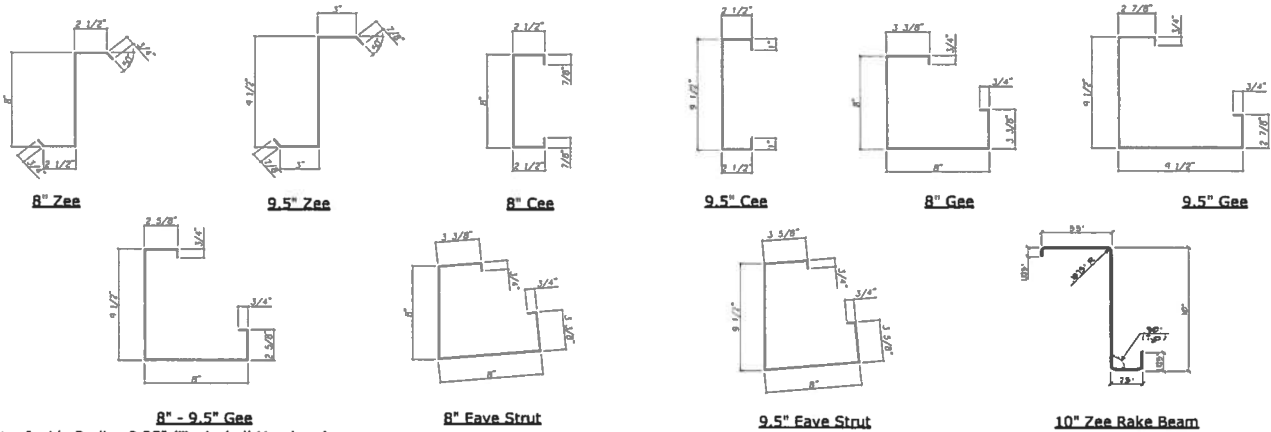

Note: Inside Radius 0.25" (Typical all Members).

**SECTION PROPERTIES**

Size	T In	W lb/ft	A <sub>p</sub> In <sup>2</sup>	A <sub>o</sub> In <sup>2</sup>	I <sub>xe</sub> In <sup>4</sup>	I <sub>x-Defn</sub> In <sup>4</sup>	S <sub>xe</sub> In <sup>3</sup>	M <sub>a</sub> k-in	M <sub>b</sub> k-ft	V <sub>a</sub> k
<b>ZEE</b>										
8 Z 16	0.060	2.87	0.84	0.45	7.36	8.09	1.74	57.25	4.77	2.60
8 Z 15	0.067	3.20	0.94	0.53	8.27	8.99	1.97	64.74	5.39	3.63
8 Z 14	0.075	3.59	1.05	0.64	9.42	10.02	2.27	74.69	6.22	5.11
8 Z 13	0.089	4.26	1.25	0.84	11.45	11.80	2.81	92.45	7.70	8.57
8 Z 12	0.099	4.73	1.39	0.98	12.79	13.05	3.15	103.87	8.66	10.82
9.5 Z 15	0.067	3.82	1.12	0.57	13.44	15.28	2.61	85.96	7.16	3.02
9.5 Z 14	0.075	4.27	1.26	0.67	15.49	17.04	3.08	101.54	8.46	4.24
9.5 Z 13	0.089	5.07	1.49	0.87	18.65	20.78	3.75	123.60	10.30	7.11
9.5 Z 12	0.099	5.64	1.66	1.05	21.17	22.24	4.32	142.28	11.86	9.81
<b>CEE</b>										
8 C 16	0.060	2.87	0.84	0.48	7.47	7.94	1.80	59.27	4.94	2.60
8 C 15	0.067	3.20	0.94	0.56	8.42	8.82	2.05	67.38	5.62	3.63
8 C 14	0.075	3.59	1.05	0.71	9.75	9.81	2.37	78.12	6.51	5.11
8 C 13	0.089	4.26	1.25	0.89	11.52	11.53	2.88	94.85	7.90	8.57
8 C 12	0.099	4.73	1.39	1.02	12.73	12.73	3.18	104.83	8.74	10.82
9.5 C 15	0.067	3.59	1.05	0.62	13.28	13.53	2.76	91.10	7.59	3.02
9.5 C 14	0.075	4.26	1.25	0.71	15.06	15.68	3.06	100.75	8.40	4.24
9.5 C 13	0.089	5.03	1.48	0.93	18.21	18.81	3.76	123.80	10.32	7.11
9.5 C 12	0.099	5.25	1.54	1.06	19.59	19.59	4.13	135.81	11.32	9.81
<b>GEE</b>										
GP 8X8X16 (Gravity, +ve)	0.060	4.76	1.41	0.64	9.82	11.14	4.13	57.54	4.80	3.58
(Uplift, -ve)	-	-	-	-	9.75	10.48	2.34	77.02	6.42	-
GP 9.5X9.5X14 (Gravity, +ve)	0.075	6.44	1.89	0.90	19.17	22.17	7.43	91.90	7.66	5.30
(Uplift, -ve)	-	-	-	-	18.66	19.96	3.82	114.28	9.52	-
GPX 8X9.5X16 (Gravity, +ve)	0.060	4.76	1.41	0.63	13.64	15.75	5.20	65.29	5.44	2.65
(Uplift, -ve)	-	-	-	-	13.74	14.71	2.62	86.46	7.21	-
<b>EAVE STRUT</b>										
GE 8X8X16 1:12 (Gravity, +ve)	0.060	4.76	1.41	0.64	9.36	10.65	1.68	55.56	4.63	3.59
(Uplift, -ve)	-	-	-	-	9.29	9.93	2.20	72.06	6.01	-
GE 8X8X16 4:12 (Gravity, +ve)	0.060	4.75	1.40	0.64	8.79	9.56	1.63	53.74	4.48	3.86
(Uplift, -ve)	-	-	-	-	8.25	8.98	1.81	59.72	4.98	-
GE 9.5X8X14 1:12 (Gravity, +ve)	0.075	6.44	1.89	0.92	18.28	20.87	2.81	92.54	7.71	5.69
(Uplift, -ve)	-	-	-	-	18.98	20.24	3.65	120.20	10.02	-
GE 9.5X8X14 4:12 (Gravity, +ve)	0.075	6.42	1.89	0.92	17.01	18.57	2.65	87.35	7.28	6.05
(Uplift, -ve)	-	-	-	-	17.38	18.40	3.20	105.46	8.79	-
<b>ZEE RAKE BEAM</b>										
ER 10X14 (Gravity, +ve)	0.075	4.96	1.46	0.76	18.04	19.59	3.68	116.64	9.72	4.02
(Uplift, -ve)	-	-	-	-	20.65	22.03	3.43	112.83	9.40	-
EH 10X12 (Gravity, +ve)	0.102	6.70	1.97	1.18	25.30	27.36	5.30	159.23	13.27	10.16
(Uplift, -ve)	-	-	-	-	29.53	29.53	4.83	168.60	14.05	-

**Notes -**

- Section properties are calculated in accordance with the 2012 North American Specification for the Design of Cold-Formed Steel Members. F<sub>y</sub> = 55 ksi.
- Bending allowables shown may be utilized for members having the compression flange continuously fastened to sheathing.
- Effective section properties are calculated at yield stress of F<sub>y</sub> = 55 ksi. Deflection Moment of Inertia, I<sub>x-Defn</sub> is calculated at working stress level of 0.6 F<sub>y</sub>.

NUCOR BUILDINGS GROUP

Job # : C22B0182A  
 Job Name : Nucor Buildings Group  
 Frame : E01  
 Date : 8/23/2022  
 Designer : BG\Viviana.Perez  
 File : E01.nfr  
 App Version : 1.6.127.0

-----  
 F R A M E D E S C R I P T I O N  
 -----

Frame type : RCG  
 Frame width : 105.00 Ft.  
 Bay width : 12.60 Ft.

	LEFT	RIGHT		
Dim to ridge :	52.50 Ft.	52.50 Ft.		
Roof slope :	1.00/12	-1.00/12		
Eave height :	20.00 Ft.	20.00 Ft.		
Girt offset :	12.00 In.	8.00 In.	Typ. Girt spacing :	5.00 Ft.
Purlin offset :	8.00 In.	8.00 In.	Typ. Purlin spacing:	5.00 Ft.

Col. spacing : 105.0000

Supports / Spring Constants

COL01 - Bottom V H  
 COL02 - Bottom V H

Column Bracing:

WP1 Girt Brace : Y  
 Flange Brace : 1  
 Location (ft): 13.5

WP2 Girt Brace : Y Y  
 Flange Brace : 1 1  
 Location (ft): 7.3 13.5

Other Braces:

Column :  
 Left Brace :  
 Right Brace :  
 Location (ft):

-----  
 L O A D I N G C O N D I T I O N S  
 -----

Building Code & Year : IBC2018  
 Risk Category : III-Substantial Hazard  
 AISC Specification : 2016 ASD

L O A D S (Psf)

Roof Dead load : 2.50  
 Roof Coll load : 5.00  
 Roof Live load : 12.00  
 Roof Snow load : 0.00  
 Floor dead load : 0.00  
 Floor live load : 0.00  
 Ground Snow load: 0.00 Ce = 1.00  
 Ss = 0.539 S1 = 0.246 Seismic Design Category = D Site Class = D  
 R = 3.50 Cd = 3.00 Sds = 0.492 Sd1 = 0.346 rho = 1.30 omega = 2.500

Is Building Irregular = False

Roof Seismic Factor : 0.176 PSF  
 Floor Seismic Factor : 0.176 PSF

Wind speed : 110.00 Mph Exp. : C  
 Wind pressure : 23.75 Psf

Building is Enclosed

# FRAME LINE 1,7

Wind pressure coefficients      Is End Bay? True

	C1	C2E	C2	C3	C3E	C4
W1R	0.790	0.000	-0.890	-0.350	0.000	-0.250
W1L	-0.250	0.000	-0.350	-0.890	0.000	0.790
W2R	0.430	0.000	-1.250	-0.710	0.000	-0.610
W2L	-0.610	0.000	-0.710	-1.250	0.000	0.430
W5B	-0.300	0.000	-0.890	-0.350	0.000	-0.300
W5F	-0.300	0.000	-0.350	-0.890	0.000	-0.300
W6B	-0.660	0.000	-1.250	-0.710	0.000	-0.660
W6F	-0.660	0.000	-0.710	-1.250	0.000	-0.660

Tributary Widths

Panel	Trib. Width (ft)
WP1	12.60
WP2	12.60
RP1	12.60
RP2	12.60

-----  
P R O G R A M - A P P L I E D   L O A D S  
-----

Panel Loads

Load Case	On Panel	Start Load Klf	End Load Klf	Start Loc Ft.	End Loc Ft.
RDL	RP1	-0.032	-0.032	0.000	52.500
RDL	RP2	-0.032	-0.032	52.500	105.000
COL	RP1	-0.063	-0.063	0.000	52.500
COL	RP2	-0.063	-0.063	52.500	105.000
RLL	RP1	-0.151	-0.151	0.000	52.500
RLR	RP2	-0.151	-0.151	52.500	105.000
W1R	WP1	0.236	0.236	0.000	20.000
W1R	WP2	0.075	0.075	0.000	20.000
W1R	RP1	-0.266	-0.266	0.000	52.500
W1R	RP2	-0.105	-0.105	52.500	105.000
W1L	WP1	-0.075	-0.075	0.000	20.000
W1L	WP2	-0.236	-0.236	0.000	20.000
W1L	RP1	-0.105	-0.105	0.000	52.500
W1L	RP2	-0.266	-0.266	52.500	105.000
W2R	WP1	0.129	0.129	0.000	20.000
W2R	WP2	0.183	0.183	0.000	20.000
W2R	RP1	-0.374	-0.374	0.000	52.500
W2R	RP2	-0.212	-0.212	52.500	105.000
W2L	WP1	-0.183	-0.183	0.000	20.000
W2L	WP2	-0.129	-0.129	0.000	20.000
W2L	RP1	-0.212	-0.212	0.000	52.500
W2L	RP2	-0.374	-0.374	52.500	105.000
W5B	WP1	-0.090	-0.090	0.000	20.000
W5B	WP2	0.090	0.090	0.000	20.000
W5B	RP1	-0.266	-0.266	0.000	52.500
W5B	RP2	-0.105	-0.105	52.500	105.000
W5F	WP1	-0.090	-0.090	0.000	20.000
W5F	WP2	0.090	0.090	0.000	20.000
W5F	RP1	-0.105	-0.105	0.000	52.500
W5F	RP2	-0.266	-0.266	52.500	105.000
W6B	WP1	-0.197	-0.197	0.000	20.000
W6B	WP2	0.197	0.197	0.000	20.000
W6B	RP1	-0.374	-0.374	0.000	52.500
W6B	RP2	-0.212	-0.212	52.500	105.000
W6F	WP1	-0.197	-0.197	0.000	20.000
W6F	WP2	0.197	0.197	0.000	20.000
W6F	RP1	-0.212	-0.212	0.000	52.500
W6F	RP2	-0.374	-0.374	52.500	105.000
EQR	RP1	0.030	0.030	0.000	52.500
EQR	RP2	0.030	0.030	52.500	105.000
EQL	RP1	-0.030	-0.030	0.000	52.500
EQL	RP2	-0.030	-0.030	52.500	105.000

-----  
U S E R - A P P L I E D   L O A D S  
-----

-----  
 Shear loads that are applied perpendicular to the web have been considered in the baseplate design only. The locations listed below for each longitudinal bracing load apply only to the column axial load (tension on base of column and compression when at top of column).

Load Case	On Mem	Hor. Kips	Vert. Kips	Perp Shear Kips	Moment K-Ft.	Loc Ft.	Special Load #	Description
RDL	SPAN1	0.000	-0.600	0.000	0.000	21.000	C-1	Hang Post
RDL	SPAN1	0.000	-0.750	0.000	0.000	42.000	C-3	Hang Post
RDL	SPAN2	0.000	-0.750	0.000	0.000	63.000	C-4	Hang Post
RDL	SPAN2	0.000	-0.600	0.000	0.000	84.000	C-2	Hang Post

-----  
 L O A D C O M B I N A T I O N S  
 -----

ASR Cases

- 1) 1.00 SW+RDL+COL+NLL
- 2) 1.00 SW+RDL+COL+NLR
- 3) 1.00 SW+RDL+COL+RLL+RLR+NLL
- 4) 1.00 SW+RDL+COL+RLL+RLR+NLR
- 5) 1.00 SW+RDL+COL+0.60W1L
- 6) 1.00 SW+RDL+COL+0.60W2L
- 7) 1.00 SW+RDL+COL+0.60W1R
- 8) 1.00 SW+RDL+COL+0.60W2R
- 9) 1.00 0.60SW+0.60RDL+0.60W1L
- 10) 1.00 0.60SW+0.60RDL+0.60W2L
- 11) 1.00 0.60SW+0.60RDL+0.60W1R
- 12) 1.00 0.60SW+0.60RDL+0.60W2R
- 13) 1.00 SW+RDL+COL+0.75RLL+0.75RLR+0.45W1L
- 14) 1.00 SW+RDL+COL+0.75RLL+0.75RLR+0.45W2L
- 15) 1.00 SW+RDL+COL+0.75RLL+0.75RLR+0.45W1R
- 16) 1.00 SW+RDL+COL+0.75RLL+0.75RLR+0.45W2R
- 17) 1.00 SW+RDL+COL+0.60W5B
- 18) 1.00 SW+RDL+COL+0.60W6B
- 19) 1.00 SW+RDL+COL+0.60W5F
- 20) 1.00 SW+RDL+COL+0.60W6F
- 21) 1.00 0.60SW+0.60RDL+0.60W5B
- 22) 1.00 0.60SW+0.60RDL+0.60W6B
- 23) 1.00 0.60SW+0.60RDL+0.60W5F
- 24) 1.00 0.60SW+0.60RDL+0.60W6F
- 25) 1.00 SW+RDL+COL+0.75RLL+0.75RLR+0.45W5B
- 26) 1.00 SW+RDL+COL+0.75RLL+0.75RLR+0.45W6B
- 27) 1.00 SW+RDL+COL+0.75RLL+0.75RLR+0.45W5F
- 28) 1.00 SW+RDL+COL+0.75RLL+0.75RLR+0.45W6F
- 29) 1.00 1.07SW+1.07RDL+1.07COL+0.91EQL
- 30) 1.00 1.07SW+1.07RDL+1.07COL+0.91EQR
- 31) 1.00 1.05SW+1.05RDL+1.05COL+0.68EQL
- 32) 1.00 1.05SW+1.05RDL+1.05COL+0.68EQR
- 33) 1.00 0.53SW+0.53RDL+0.91EQL
- 34) 1.00 0.53SW+0.53RDL+0.91EQR



# FRAME LINE 1,7

Job : C22B0182A      Nucor Buildings Group  
 Frame: E01

NUCOR BUILDINGS GROUP

Date: 08-29-22  
 By : BG\Viviana.Perez

Page: 1  
 File: E01

\*\*\* DESIGN SUMMARY REPORT \*\*\*

-----  
 Built Up Rafter - RAF01

Section	T/L	B/R	Load	Comb	Loc	Axial Kips	Axial Ratio	Moment Ft-kip	T/L	B/R	Max Unity Check	SHEAR					
	Flange Mat'l	Flange Mat'l							Web Mat'l	Bend Ratio		Bend Ratio	Load Comb	Loc	Force Kips	Shear Ratio	Flow (k/in) T/L    B/R
1	F6.31	F6.38	W188	3	1	-15.4	0.13	-216.1	0.71	0.83	0.89	3	1	12.81	0.32	0.23	0.26

Chkpt            1                            5  
 Depth 36.69                            28.69  
 Section |                            1                            |

| width thick    Fy    |

-----  
 T/L Flg |    6.0 0.3125 55.00 |  
 Web    |            0.1875 55.00 |  
 B/R Flg |    6.0 0.3750 55.00 |  
 -----

Built Up Rafter - RAF02

Section	T/L	B/R	Load	Comb	Loc	Axial Kips	Axial Ratio	Moment Ft-kip	T/L	B/R	Max Unity Check	SHEAR					
	Flange Mat'l	Flange Mat'l							Web Mat'l	Bend Ratio		Bend Ratio	Load Comb	Loc	Force Kips	Shear Ratio	Flow (k/in) T/L    B/R
1	F5.25	F5.25	W135	4	12	-14.2	0.41	74.0	0.66	0.52	1.00	3	6	9.23	0.44	0.22	0.22
2	F5.25	F5.25	W188	4	16	-14.0	0.36	94.1	0.68	0.58	0.97	3	13	3.34	0.08	0.07	0.07

Chkpt            6                            12    13                            18  
 Depth 28.50                            28.50                            28.50  
 Section |                            1                            |                            2                            |

| width thick    Fy    | width thick    Fy    |

-----  
 T/L Flg |    5.0 0.2500 55.00 |    5.0 0.2500 55.00 |  
 Web    |            0.1345 55.00 |            0.1875 55.00 |  
 B/R Flg |    5.0 0.2500 55.00 |    5.0 0.2500 55.00 |  
 -----

Built Up Rafter - RAF03

Section	T/L	B/R	Load	Comb	Loc	Axial Kips	Axial Ratio	Moment Ft-kip	T/L	B/R	Max Unity Check	SHEAR					
	Flange Mat'l	Flange Mat'l							Web Mat'l	Bend Ratio		Bend Ratio	Load Comb	Loc	Force Kips	Shear Ratio	Flow (k/in) T/L    B/R
1	F5.25	F5.25	W188	3	21	-14.0	0.36	94.6	0.68	0.58	0.97	4	24	-3.25	0.08	0.07	0.07
2	F5.25	F5.25	W135	3	25	-14.2	0.41	75.3	0.67	0.52	1.01	4	31	-9.14	0.44	0.22	0.22

Chkpt            19                            24    25                            31  
 Depth 28.50                            28.50                            28.50  
 Section |                            1                            |                            2                            |

| width thick    Fy    | width thick    Fy    |

-----  
 T/L Flg |    5.0 0.2500 55.00 |    5.0 0.2500 55.00 |  
 Web    |            0.1875 55.00 |            0.1345 55.00 |  
 B/R Flg |    5.0 0.2500 55.00 |    5.0 0.2500 55.00 |  
 -----

Built Up Rafter - RAF04

Section	T/L	B/R	Load	Comb	Loc	Axial Kips	Axial Ratio	Moment Ft-kip	T/L	B/R	Max Unity Check	SHEAR					
	Flange Mat'l	Flange Mat'l							Web Mat'l	Bend Ratio		Bend Ratio	Load Comb	Loc	Force Kips	Shear Ratio	Flow (k/in) T/L    B/R
1	F6.25	F6.31	W188	4	36	-15.3	0.16	-215.9	0.81	0.95	1.03	4	36	-12.71	0.31	0.21	0.24

Chkpt            32                            36  
 Depth 28.56                            36.56  
 Section |                            1                            |

| width thick    Fy    |

-----  
 T/L Flg |    6.0 0.2500 55.00 |  
 Web    |            0.1875 55.00 |  
 B/R Flg |    6.0 0.3125 55.00 |  
 -----

Built Up Column - COL01

Section	T/L	B/R	Load	Comb	Loc	Axial Kips	Axial Ratio	Moment Ft-kip	T/L	B/R	Max Unity Check	SHEAR					
	Flange Mat'l	Flange Mat'l							Web Mat'l	Bend Ratio		Bend Ratio	Load Comb	Loc	Force Kips	Shear Ratio	Flow (k/in) T/L    B/R
1	F8.25	F8.31	W188	3	42	-16.5	0.11	-215.4	0.71	0.84	0.90	3	42	-12.93	0.32	0.92	0.99

Chkpt            37                            42  
 Depth 12.00                            35.56  
 Section |                            1                            |

| width thick    Fy    |

-----  
 T/L Flg |    8.0 0.2500 55.00 |  
 Web    |            0.1875 55.00 |  
 B/R Flg |    8.0 0.3125 55.00 |  
 -----

# FRAME LINE 1,7

Built Up Column - COL02

Section	T/L	B/R	Web	Load	Loc	Axial	Axial	Moment	T/L	B/R	Max	-----		SHEAR		-----	
	Flange	Flange							Bend	Bend		Unity	Load	Loc	Force	Shear	Flow
	Mat'l	Mat'l	Mat'l	Comb		Kips	Ratio	Ft-kip	Ratio	Ratio	Check	Comb	Loc	Kips	Ratio	T/L	B/R
1	F8.31	F8.25	W188	4	49	-16.4	0.11	215.6	0.84	0.71	0.90	4	49	12.94	0.32	0.99	0.92

-----  
 Chkpt            43                    49  
 Depth 12.00                    35.56  
 Section |                    1                    |

| width thick    Fy    |

-----  
 T/L Flg | 8.0 0.3125 55.00 |  
 Web     |     0.1875 55.00 |  
 B/R Flg | 8.0 0.2500 55.00 |  
 -----

Frame Weight (lbs) =    3569

Deflections (in):

10 yr Wind dx =	-0.47 = H/	422	LONG. WIND 2 TO BACK
Seismic dx =	0.59 = H/	337	SEISMIC TO RIGHT
Story Drift =	1.42 =	0.007H	SEISMIC TO RIGHT
Stability Coefficient =	0.01		1.07SW+1.07RDL+1.07COL+0.91EQR
Stability Ratio =	0.04		1.07SW+1.07RDL+1.07COL+0.91EQR
Fundamental Period =	0.5575		Single Story Period
Maximum dx =	0.77 = H/	256	1.07SW+1.07RDL+1.07COL+0.91EQR
Maximum dy =	-4.44 = L/	270 @ MOD 1,	SW+RDL+COL+RLL+RLR
Max. Live dy =	-2.20 = L/	545 @ MOD 1,	LIVE ON LEFT AND RIGHT

Job # : C22B0182A  
 File : E01.nfr  
 App Version : 1.6.127.0

Job Name : Nucor Buildings Group  
 Designer : BG\Viviana.Perez  
 Date : 8/23/2022

Frame : E01

**BOLTED END-PLATES (BEP) SUMMARY**

**Bolt Pre Tension Method : TurnOfNut**

**PLATE SIZE: (in)**

Splice ID	Left Type	Right Type	Members Joined	Web Loc	Web Depth	Left Plate				Right Plate			
						Width	Thick	Length	Fy(ksi)	Width	Thick	Length	Fy(ksi)
1	6E	6E	COL01 To RAF01	Top	36.00	8.00	0.50	42.00	55.0	6.00	0.50	42.00	55.0
1	6E	6E	COL01 To RAF01	Bot	36.00	8.00	0.50	42.00	55.0	6.00	0.50	42.00	55.0
2	4E	4E	RAF01 To RAF02	Top	28.00	6.00	0.38	34.00	55.0	6.00	0.38	34.00	55.0
2	4E	4E	RAF01 To RAF02	Bot	28.00	6.00	0.38	34.00	55.0	6.00	0.38	34.00	55.0
3	4E	4E	RAF02 To RAF03	Top	28.00	6.00	0.38	33.85	55.0	6.00	0.38	33.85	55.0
3	4E	4E	RAF02 To RAF03	Bot	28.00	6.00	0.38	33.85	55.0	6.00	0.38	33.85	55.0
4	4E	4E	RAF03 To RAF04	Top	28.00	6.00	0.38	33.75	55.0	6.00	0.38	33.75	55.0
4	4E	4E	RAF03 To RAF04	Bot	28.00	6.00	0.38	33.75	55.0	6.00	0.38	33.75	55.0
5	6E	6E	RAF04 To COL02	Top	36.00	6.00	0.50	42.00	55.0	8.00	0.50	42.00	55.0
5	6E	6E	RAF04 To COL02	Bot	36.00	6.00	0.50	42.00	55.0	8.00	0.50	42.00	55.0

**PLATE DESIGN**

Splice ID	Left Type	Right Type	Tension Location	Load Comb	Max Moment			Load Comb	Max Shear			Left Plate Ratio	Right Plate Ratio
					Axial (kip)	Shear (kip)	Moment (ft-kip)		Axial (kip)	Shear (kip)	Moment (ft-kip)		
1	6E	6E	Top	2	-13.87	14.41	-216.09	10	5.47	-7.25	94.58	0.74	0.88
1	6E	6E	Bot	10	5.47	-7.25	94.58	2	-13.87	14.41	-216.09	0.38	0.46
2	4E	4E	Top	2	-14.69	9.25	-59.63	10	6.10	-4.13	18.52	0.50	0.51
2	4E	4E	Bot	22	7.30	-3.06	37.30	2	-14.69	9.25	-59.63	0.54	0.56
3	4E	4E	Top	8	6.37	-0.98	-34.15	15	-0.88	1.33	13.76	0.49	0.49
3	4E	4E	Bot	2	-13.87	0.03	92.34	22	7.38	-1.34	-31.59	0.89	0.89
4	4E	4E	Top	2	-14.68	-9.16	-56.55	8	6.11	4.08	16.58	0.46	0.46
4	4E	4E	Bot	20	7.27	3.02	35.40	2	-14.68	-9.16	-56.55	0.52	0.51
5	6E	6E	Top	2	-13.87	-14.30	-215.92	8	5.48	7.22	94.39	0.89	0.74
5	6E	6E	Bot	8	5.48	7.22	94.39	2	-13.87	-14.30	-215.92	0.47	0.38

**BOLT RUPTURE DESIGN**

Splice ID	Left Type	Right Type	Bolt Loc	Pre-Tension	Dia	Gage	Gage 2	Pfi	Pfo	Pf	Pb	de	Load Comb	Axial (kip)	Moment (ft-kip)	Left Bolt Ratio	Right Bolt Ratio	
																		1
1	6E	6E	Bot	A325	Yes	0.75	3.50	--	1.31	1.31	3.00	2.25	1.25	10	5.47	94.58	0.29	0.29
2	4E	4E	Top	A325	Yes	0.75	3.50	--	1.25	1.44	3.00	--	1.25	2	-14.69	-59.63	0.22	0.23
2	4E	4E	Bot	A325	Yes	0.75	3.50	--	1.25	1.36	3.00	--	1.25	22	7.30	37.30	0.24	0.24
3	4E	4E	Top	A325	Yes	0.75	3.50	--	1.25	1.41	2.88	--	1.25	8	6.37	-34.15	0.22	0.22
3	4E	4E	Bot	A325	Yes	0.75	3.50	--	1.25	1.34	2.88	--	1.25	2	-13.87	92.34	0.40	0.40
4	4E	4E	Top	A325	Yes	0.75	3.50	--	1.25	1.38	2.88	--	1.25	2	-14.68	-56.55	0.21	0.21
4	4E	4E	Bot	A325	Yes	0.75	3.50	--	1.25	1.38	2.88	--	1.25	20	7.27	35.40	0.23	0.23
5	6E	6E	Top	A325	Yes	0.75	3.50	--	1.31	1.39	3.00	2.25	1.25	2	-13.87	-215.92	0.56	0.56
5	6E	6E	Bot	A325	Yes	0.75	3.50	--	1.31	1.44	3.00	2.25	1.25	8	5.48	94.39	0.29	0.29

**COMBINED BOLT BEARING SHEAR DESIGN**

Splice ID	Left Type	Right Type	Bolt Loc	Pre-Tension	Dia	Gage	Gage 2	Pfi	Pfo	Pf	Pb	de	Load Comb	Shear (kip)	Left Bolt Ratio	Right Bolt Ratio	
																	1
1	6E	6E	Bot	A325	Yes	0.75	3.50	--	1.31	1.31	3.00	2.25	1.25	2	14.41	0.20	0.20
2	4E	4E	Top	A325	Yes	0.75	3.50	--	1.25	1.44	3.00	--	1.25	10	-4.13	0.09	0.09

Splice ID	Left Type	Right Type	Bolt Loc	Bolt Type	Pre-Tension	Dia	Gage	Gage 2	Pfi	Pfo	Pf	Pb	de	Load Comb	Shear (kip)	Left Bolt	Right Bolt
																Ratio	Ratio
2	4E	4E	Bot	A325	Yes	0.75	3.50	--	1.25	1.36	3.00	--	1.25	2	9.25	0.19	0.19
3	4E	4E	Top	A325	Yes	0.75	3.50	--	1.25	1.41	2.88	--	1.25	15	1.33	0.03	0.03
3	4E	4E	Bot	A325	Yes	0.75	3.50	--	1.25	1.34	2.88	--	1.25	22	-1.34	0.03	0.03
4	4E	4E	Top	A325	Yes	0.75	3.50	--	1.25	1.38	2.88	--	1.25	8	4.08	0.09	0.09
4	4E	4E	Bot	A325	Yes	0.75	3.50	--	1.25	1.38	2.88	--	1.25	2	-9.16	0.19	0.19
5	6E	6E	Top	A325	Yes	0.75	3.50	--	1.31	1.39	3.00	2.25	1.25	8	7.22	0.10	0.10
5	6E	6E	Bot	A325	Yes	0.75	3.50	--	1.31	1.44	3.00	2.25	1.25	2	-14.30	0.20	0.20

WELD DESIGN

Splice ID	Loc	Left						Right							
		Welds			Checks			Welds			Checks				
		Flg	Web	Stf	Load Comb	Tensile Rupture	Load Comb	Shear Rupture	Flg	Web	Stf	Load Comb	Tensile Rupture	Load Comb	Shear Rupture
1	Top	FWD3	WP13		2	0.57	10	0.11	FWD3	WP13		2	0.78	10	0.11
1	Bot	FWD3	WP13		10	0.30	2	0.21	FWD3	WP13		10	0.41	2	0.22
2	Top	FWD3	WP13		2	0.26	10	0.08	FWD3	WP13		2	0.32	10	0.10
2	Bot	FWD3	WP13		22	0.28	2	0.19	FWD3	WP13		22	0.35	2	0.23
3	Top	FWD3	WP13		8	0.29	15	0.03	FWD3	WP13		8	0.29	15	0.03
3	Bot	FWD3	WP13		2	0.52	22	0.03	FWD3	WP13		2	0.52	22	0.03
4	Top	FWD3	WP13		2	0.30	8	0.10	FWD3	WP13		2	0.24	8	0.08
4	Bot	FWD3	WP13		20	0.33	2	0.23	FWD3	WP13		20	0.27	2	0.19
5	Top	FWD3	WP13		2	0.78	8	0.11	FWD3	WP13		2	0.57	8	0.11
5	Bot	FWD3	WP13		8	0.41	2	0.22	FWD3	WP13		8	0.30	2	0.21

BASEPLATE AND ANCHOR ROD DESIGN RESULTS

BASEPLATE AND ANCHOR ROD INFORMATION: (in)

Column ID	Column Type	Column Pattern	Column Depth	Base Plate				Anchor Rods					
				Width	Thickness	Length	Fy(ksi)	Qty	Dia.	Grade	Pfi	Pb	Gage
COL01	WF/BU	Left	12	10	0.625	12.0000	55	4	1.25	Grade36	4	5	5
COL02	WF/BU	Right	12	10	0.625	12.0000	55	4	1.25	Grade36	4	5	5

BASEPLATE DESIGN CHECKS

Column ID	Concrete Bearing (Compression)					Base Plate Yielding (Tension)				
	Load Comb	Axial (kip)	Shear (kip)	Bracing Shear (kip)	Design Ratio	Load Comb	Axial (kip)	Shear (kip)	Bracing Shear (kip)	Design Ratio
COL01	2	-16.22	-13.90	0.00	0.09	10	7.90	6.40	0.00	0.55
COL02	2	-16.08	13.84	0.00	0.09	8	7.87	-6.65	0.00	0.55

ANCHOR ROD SHEAR AND TENSION DESIGN CHECKS

Column ID	Anchor Rod Tension Design					Anchor Rod Shear Design				Combined Tension-Shear Design				Combined Shear-Tension Design						
	Load Comb	Axial (kip)	Shear (kip)	Bracing Shear (kip)	Rod Ratio	Load Comb	Axial (kip)	Shear (kip)	Bracing Shear (kip)	Rod Ratio	Load Comb	Axial (kip)	Shear (kip)	Bracing Shear (kip)	Rod Ratio	Load Comb	Axial (kip)	Shear (kip)	Bracing Shear (kip)	Rod Ratio
COL01	10	7.90	6.40	0.00	0.07	2	-16.22	-13.90	0.00	0.22	10	7.90	6.40	0.00	0.07	2	-16.22	-13.90	0.00	0.22
COL02	8	7.87	-6.65	0.00	0.07	2	-16.08	13.84	0.00	0.22	8	7.87	-6.65	0.00	0.07	2	-16.08	13.84	0.00	0.22

BASEPLATE LEFT FLANGE WELD DESIGN CHECKS

Column ID	Left Flange Weld (Pipe Weld)						Web Weld					Right Flange Weld						
	Weld Size	Load Comb	Axial (kip)	Shear (kip)	Bracing Shear (kip)	Weld Ratio	Weld Size	Load Comb	Axial (kip)	Shear (kip)	Bracing Shear (kip)	Weld Ratio	Weld Size	Load Comb	Axial (kip)	Shear (kip)	Bracing Shear (kip)	Weld Ratio
COL01	FWS3	10	7.90	6.40	0.00	0.05	FWR3	2	-16.22	-13.90	0.00	0.31	FWS3	10	7.90	6.40	0.00	0.07
COL02	FWS3	8	7.87	-6.65	0.00	0.07	FWR3	2	-16.08	13.84	0.00	0.31	FWS3	8	7.87	-6.65	0.00	0.05

No	ASR	Combination
1	1.00	1.00SW+1.00RDL+1.00COL
2	1.00	1.00SW+1.00RDL+1.00COL+1.00RLL+1.00RLR
3	1.00	1.00SW+1.00RDL+1.00COL+0.60W1L
4	1.00	1.00SW+1.00RDL+1.00COL+0.60W2L
5	1.00	1.00SW+1.00RDL+1.00COL+0.60W1R
6	1.00	1.00SW+1.00RDL+1.00COL+0.60W2R
7	1.00	0.60SW+0.60RDL+0.60W1L
8	1.00	0.60SW+0.60RDL+0.60W2L
9	1.00	0.60SW+0.60RDL+0.60W1R
10	1.00	0.60SW+0.60RDL+0.60W2R
11	1.00	1.00SW+1.00RDL+1.00COL+0.75RLL+0.75RLR+0.45W1L
12	1.00	1.00SW+1.00RDL+1.00COL+0.75RLL+0.75RLR+0.45W2L
13	1.00	1.00SW+1.00RDL+1.00COL+0.75RLL+0.75RLR+0.45W1R
14	1.00	1.00SW+1.00RDL+1.00COL+0.75RLL+0.75RLR+0.45W2R
15	1.00	1.00SW+1.00RDL+1.00COL+0.60W5B
16	1.00	1.00SW+1.00RDL+1.00COL+0.60W6B
17	1.00	1.00SW+1.00RDL+1.00COL+0.60W5F
18	1.00	1.00SW+1.00RDL+1.00COL+0.60W6F
19	1.00	0.60SW+0.60RDL+0.60W5B
20	1.00	0.60SW+0.60RDL+0.60W6B
21	1.00	0.60SW+0.60RDL+0.60W5F
22	1.00	0.60SW+0.60RDL+0.60W6F
23	1.00	1.00SW+1.00RDL+1.00COL+0.75RLL+0.75RLR+0.45W5B
24	1.00	1.00SW+1.00RDL+1.00COL+0.75RLL+0.75RLR+0.45W6B
25	1.00	1.00SW+1.00RDL+1.00COL+0.75RLL+0.75RLR+0.45W5F
26	1.00	1.00SW+1.00RDL+1.00COL+0.75RLL+0.75RLR+0.45W6F
27	1.00	1.069SW+1.069RDL+1.069COL+0.91EQL
28	1.00	1.069SW+1.069RDL+1.069COL+0.91EQR
29	1.00	1.052SW+1.052RDL+1.052COL+0.682EQL
30	1.00	1.052SW+1.052RDL+1.052COL+0.682EQR
31	1.00	0.53SW+0.53RDL+0.91EQL
32	1.00	0.53SW+0.53RDL+0.91EQR
33*	1.20	1.069SW+1.069RDL+1.069COL+1.75EQL
34*	1.20	1.052SW+1.052RDL+1.052COL+1.313EQL
35*	1.20	0.531SW+0.531RDL+0.531COL+1.75EQL
36*	1.20	1.069SW+1.069RDL+1.069COL+1.75EQR
37*	1.20	1.052SW+1.052RDL+1.052COL+1.313EQR
38*	1.20	0.531SW+0.531RDL+0.531COL+1.75EQR

\*Indicates a Special Seismic Load Combination

# FRAME LINE 1,7

F-9

Web Depth	7	36.00	8	28.00	9	28.00	CT	10	28.00	11	28.00	CT	12	28.00	13	36.00
Length on Slope		165.02		240.00		180.00		180.00		240.00		240.00		169.03		
Left/Top Flange		F6.31		F5.25		F5.25		F5.25		F5.25		F5.25		F6.25		
Web		W188		W135		W188		W188		W135		W135		W188		
Right/Bottom Flange		F6.38		F5.25		F5.25		F5.25		F5.25		F5.25		F6.31		
Horizontal Tail Dim.				17.6208				52.5000						87.3792		
Purlin Offset: 8.0		RAF01				RAF02				RAF03				RAF04		
Projected Area: 325																

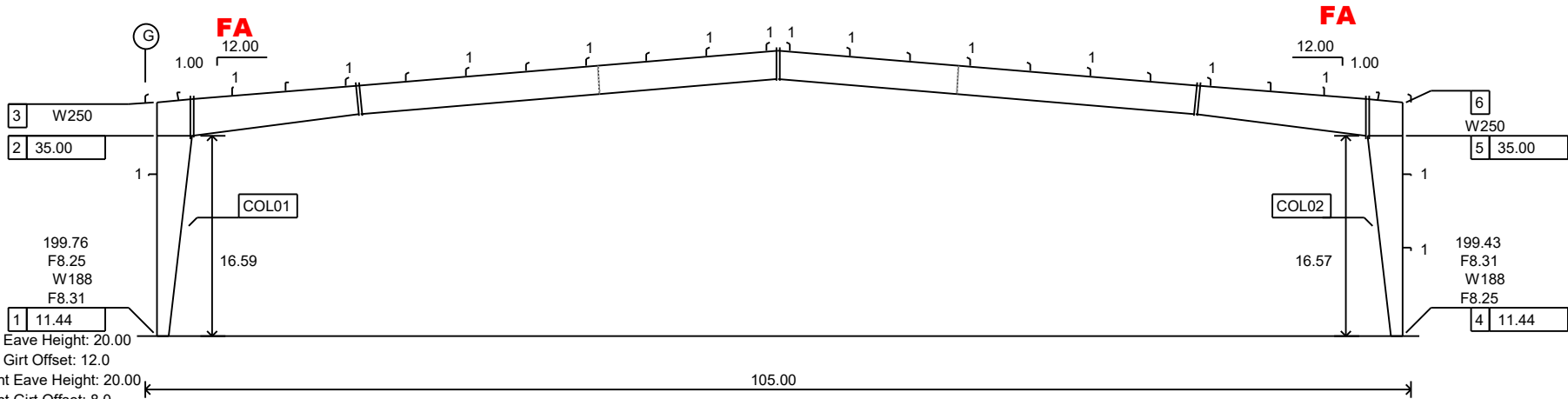

Left Eave Height: 20.00  
 Left Girt Offset: 12.0  
 Right Eave Height: 20.00  
 Right Girt Offset: 8.0

Total Width: 105.00	Frame Wt: 4402	Max Wind dx: H/422	Max dx: H/256	Max dy: L/270									
Location Code	1 P	2	3	4 P	5	6	7 M	8 M	9	10 M	11	12 M	13 M
Left Plate	NA	4x0.375	8x0.250	NA	4x0.375	8x0.250	8x0.500	6x0.375	-	6x0.375	-	6x0.375	6x0.500
Right Plate	10x0.625	-	-	10x0.625	-	-	6x0.500	6x0.375	-	6x0.375	-	6x0.375	8x0.500
Bolt Quantity-Diameter	4-1.250	-	-	4-1.250	-	-	12-0.75-S	8-0.75-S	-	8-0.75-S	-	8-0.75-S	12-0.75-S
Pfi/Pf	4.000/NA	-	-	4.000/NA	-	-	1.313/3.000	1.250/3.000	-	1.250/2.875	-	1.250/2.875	1.313/3.000
Top Welds (L/R)	FWS3	-	W1-FWS3	FWS3	-	W1-FWS3	FWD3/FWD3	FWD3/FWD3	-	FWD3/FWD3	-	FWD3/FWD3	FWD3/FWD3
Bottom Welds (L/R)	FWS3	-	W3-FWS3	FWS3	-	W3-FWS3	FWD3/FWD3	FWD3/FWD3	-	FWD3/FWD3	-	FWD3/FWD3	FWD3/FWD3
Web Welds (L/R)	FWR3	-	W4-FWS3	FWR3	-	W4-FWS3	WP13/WP13	WP13/WP13	-	WP13/WP13	-	WP13/WP13	WP13/WP13
Connection Code	BHFCNA	-	-	BHFCNA	-	-	KVEUEU	SPEUEU	-	SVEUEU	-	SPEUEU	KVEUEU
Pb/Gage	5.000/5.000	-	-	5.000/5.000	-	-	2.250/3.500	NA/3.500	-	NA/3.500	-	NA/3.500	2.250/3.500

NUCOR BUILDINGS GROUP

Job # : C22B0182A  
 Job Name : Rob Kerth Iceland  
 Frame : F01  
 Date : 8/23/2022  
 Designer : BG\Viviana.Perez  
 File : F01a.nfr  
 App Version : 1.6.127.0

-----  
 F R A M E D E S C R I P T I O N  
 -----

Frame type : RCG  
 Frame width : 105.00 Ft.  
 Bay width : 25.00 Ft.

	LEFT	RIGHT		
Dim to ridge :	52.50 Ft.	52.50 Ft.		
Roof slope :	1.00/12	-1.00/12		
Eave height :	20.00 Ft.	20.00 Ft.		
Girt offset :	12.00 In.	8.00 In.	Typ. Girt spacing :	5.00 Ft.
Purlin offset :	8.00 In.	8.00 In.	Typ. Purlin spacing:	5.00 Ft.

Col. spacing : 105.0000

Supports / Spring Constants

COL01 - Bottom V H  
 COL02 - Bottom V H

Column Bracing:

WP1 Girt Brace : Y  
 Flange Brace : 2  
 Location (ft): 13.5

WP2 Girt Brace : Y Y  
 Flange Brace : 2 2  
 Location (ft): 7.3 13.5

Other Braces:

Column :  
 Left Brace :  
 Right Brace :  
 Location (ft):

-----  
 L O A D I N G C O N D I T I O N S  
 -----

Building Code & Year : IBC2018  
 Risk Category : III-Substantial Hazard  
 AISC Specification : 2016 ASD

L O A D S (Psf)

Roof Dead load : 2.50  
 Roof Coll load : 5.00  
 Roof Live load : 12.00  
 Roof Snow load : 0.00  
 Floor dead load : 0.00  
 Floor live load : 0.00  
 Ground Snow load: 0.00 Ce = 1.00  
 Ss = 0.539 S1 = 0.246 Seismic Design Category = D Site Class = D  
 R = 3.50 Cd = 3.00 Sds = 0.492 Sd1 = 0.346 rho = 1.30 omega = 2.500

Is Building Irregular = False

Roof Seismic Factor : 0.176 PSF  
 Floor Seismic Factor : 0.176 PSF

Wind speed : 110.00 Mph Exp. : C  
 Wind pressure : 23.75 Psf

Building is Enclosed

Wind pressure coefficients      Is End Bay? False

	C1	C2E	C2	C3	C3E	C4
W1R	0.580	0.000	-0.510	-0.190	0.000	-0.110
W1L	-0.110	0.000	-0.190	-0.510	0.000	0.580
W2R	0.220	0.000	-0.870	-0.550	0.000	-0.470
W2L	-0.470	0.000	-0.550	-0.870	0.000	0.220
W5B	-0.270	0.000	-0.510	-0.190	0.000	-0.270
W5F	-0.270	0.000	-0.190	-0.510	0.000	-0.270
W6B	-0.630	0.000	-0.870	-0.550	0.000	-0.630
W6F	-0.630	0.000	-0.550	-0.870	0.000	-0.630

Tributary Widths

Panel	Trib. Width (ft)
WP1	25.00
WP2	25.00
RP1	25.00
RP2	25.00

-----  
P R O G R A M - A P P L I E D   L O A D S  
-----

Panel Loads

Load Case	On Panel	Start Load Klf	End Load Klf	Start Loc Ft.	End Loc Ft.
RDL	RP1	-0.063	-0.063	0.000	52.500
RDL	RP2	-0.063	-0.063	52.500	105.000
COL	RP1	-0.125	-0.125	0.000	52.500
COL	RP2	-0.125	-0.125	52.500	105.000
RLL	RP1	-0.300	-0.300	0.000	52.500
RLR	RP2	-0.300	-0.300	52.500	105.000
W1R	WP1	0.344	0.344	0.000	20.000
W1R	WP2	0.065	0.065	0.000	20.000
W1R	RP1	-0.303	-0.303	0.000	52.500
W1R	RP2	-0.113	-0.113	52.500	105.000
W1L	WP1	-0.065	-0.065	0.000	20.000
W1L	WP2	-0.344	-0.344	0.000	20.000
W1L	RP1	-0.113	-0.113	0.000	52.500
W1L	RP2	-0.303	-0.303	52.500	105.000
W2R	WP1	0.131	0.131	0.000	20.000
W2R	WP2	0.279	0.279	0.000	20.000
W2R	RP1	-0.516	-0.516	0.000	52.500
W2R	RP2	-0.327	-0.327	52.500	105.000
W2L	WP1	-0.279	-0.279	0.000	20.000
W2L	WP2	-0.131	-0.131	0.000	20.000
W2L	RP1	-0.327	-0.327	0.000	52.500
W2L	RP2	-0.516	-0.516	52.500	105.000
W5B	WP1	-0.160	-0.160	0.000	20.000
W5B	WP2	0.160	0.160	0.000	20.000
W5B	RP1	-0.303	-0.303	0.000	52.500
W5B	RP2	-0.113	-0.113	52.500	105.000
W5F	WP1	-0.160	-0.160	0.000	20.000
W5F	WP2	0.160	0.160	0.000	20.000
W5F	RP1	-0.113	-0.113	0.000	52.500
W5F	RP2	-0.303	-0.303	52.500	105.000
W6B	WP1	-0.374	-0.374	0.000	20.000
W6B	WP2	0.374	0.374	0.000	20.000
W6B	RP1	-0.516	-0.516	0.000	52.500
W6B	RP2	-0.327	-0.327	52.500	105.000
W6F	WP1	-0.374	-0.374	0.000	20.000
W6F	WP2	0.374	0.374	0.000	20.000
W6F	RP1	-0.327	-0.327	0.000	52.500
W6F	RP2	-0.516	-0.516	52.500	105.000
EQR	RP1	0.051	0.051	0.000	52.500
EQR	RP2	0.051	0.051	52.500	105.000
EQL	RP1	-0.051	-0.051	0.000	52.500
EQL	RP2	-0.051	-0.051	52.500	105.000

Concentrated Loads

-----



Load Case	On Mem	Hor. Kips	Vert. Kips	Moment K-Ft.	Loc Ft.
W1R	COL01	0.757	0.000	0.000	20.000
W1R	COL02	0.757	0.000	0.000	20.000
W1L	COL01	-0.757	0.000	0.000	20.000
W1L	COL02	-0.757	0.000	0.000	20.000
W2R	COL01	0.757	0.000	0.000	20.000
W2R	COL02	0.757	0.000	0.000	20.000
W2L	COL01	-0.757	0.000	0.000	20.000
W2L	COL02	-0.757	0.000	0.000	20.000

-----  
 Endwall Bracing Loads  
 -----

Shear loads that are applied perpendicular to the web have been considered in the baseplate design only.

Load Case	On Mem	Hor. Kips	Vert. Kips	Perp Shear Kips	Moment K-Ft.	Loc Ft.
-----------	--------	-----------	------------	-----------------	--------------	---------

-----  
 U S E R - A P P L I E D L O A D S  
 -----

Shear loads that are applied perpendicular to the web have been considered in the baseplate design only. The locations listed below for each longitudinal bracing load apply only to the column axial load (tension on base of column and compression when at top of column).

Load Case	On Mem	Hor. Kips	Vert. Kips	Perp Shear Kips	Moment K-Ft.	Loc Ft.	Special Load #	Description
BWF	COL01	0.000	4.500	-5.500	0.000	0.500	Long. Bracing-1	COL01
BWF	COL02	0.000	4.500	-5.500	0.000	0.500	Long. Bracing-2	COL02
BWB	COL01	0.000	-4.500	5.500	0.000	18.500	Long. Bracing-1	COL01
BWB	COL02	0.000	-4.500	5.500	0.000	18.500	Long. Bracing-2	COL02
EQB	COL01	0.000	-7.750	9.500	0.000	18.500	Long. Bracing-1	COL01
EQB	COL02	0.000	-7.750	9.500	0.000	18.500	Long. Bracing-2	COL02
EQF	COL01	0.000	7.750	-9.500	0.000	0.500	Long. Bracing-1	COL01
EQF	COL02	0.000	7.750	-9.500	0.000	0.500	Long. Bracing-2	COL02

-----  
 L O A D C O M B I N A T I O N S  
 -----

ASR Cases

- 1) 1.00 SW+RDL+COL+NLL
- 2) 1.00 SW+RDL+COL+NLR
- 3) 1.00 SW+RDL+COL+RLL+RLR+NLL
- 4) 1.00 SW+RDL+COL+RLL+RLR+NLR
- 5) 1.00 SW+RDL+COL+0.60W1L
- 6) 1.00 SW+RDL+COL+0.60W2L
- 7) 1.00 SW+RDL+COL+0.60W1R
- 8) 1.00 SW+RDL+COL+0.60W2R
- 9) 1.00 0.60SW+0.60RDL+0.60W1L
- 10) 1.00 0.60SW+0.60RDL+0.60W2L
- 11) 1.00 0.60SW+0.60RDL+0.60W1R
- 12) 1.00 0.60SW+0.60RDL+0.60W2R
- 13) 1.00 SW+RDL+COL+0.75RLL+0.75RLR+0.45W1L
- 14) 1.00 SW+RDL+COL+0.75RLL+0.75RLR+0.45W2L
- 15) 1.00 SW+RDL+COL+0.75RLL+0.75RLR+0.45W1R
- 16) 1.00 SW+RDL+COL+0.75RLL+0.75RLR+0.45W2R
- 17) 1.00 SW+RDL+COL+0.60W5B+0.60BWB
- 18) 1.00 SW+RDL+COL+0.60W6B+0.60BWB
- 19) 1.00 SW+RDL+COL+0.60W5F+0.60BWF
- 20) 1.00 SW+RDL+COL+0.60W6F+0.60BWF
- 21) 1.00 0.60SW+0.60RDL+0.60W5B+0.60BWB
- 22) 1.00 0.60SW+0.60RDL+0.60W6B+0.60BWB
- 23) 1.00 0.60SW+0.60RDL+0.60W5F+0.60BWF
- 24) 1.00 0.60SW+0.60RDL+0.60W6F+0.60BWF
- 25) 1.00 SW+RDL+COL+0.75RLL+0.75RLR+0.45W5B+0.45BWB
- 26) 1.00 SW+RDL+COL+0.75RLL+0.75RLR+0.45W6B+0.45BWB
- 27) 1.00 SW+RDL+COL+0.75RLL+0.75RLR+0.45W5F+0.45BWF
- 28) 1.00 SW+RDL+COL+0.75RLL+0.75RLR+0.45W6F+0.45BWF
- 29) 1.00 1.07SW+1.07RDL+1.07COL+0.91EQL
- 30) 1.00 1.07SW+1.07RDL+1.07COL+0.91EQR
- 31) 1.00 1.07SW+1.07RDL+1.07COL+0.91EQB+NLL

32) 1.00 1.07SW+1.07RDL+1.07COL+0.91EQB+NLR  
33) 1.00 1.07SW+1.07RDL+1.07COL+0.91EQF+NLL  
34) 1.00 1.07SW+1.07RDL+1.07COL+0.91EQF+NLR  
35) 1.00 1.05SW+1.05RDL+1.05COL+0.68EQL  
36) 1.00 1.05SW+1.05RDL+1.05COL+0.68EQR  
37) 1.00 1.05SW+1.05RDL+1.05COL+0.68EQB+NLL  
38) 1.00 1.05SW+1.05RDL+1.05COL+0.68EQB+NLR  
39) 1.00 1.05SW+1.05RDL+1.05COL+0.68EQF+NLL  
40) 1.00 1.05SW+1.05RDL+1.05COL+0.68EQF+NLR  
41) 1.00 0.53SW+0.53RDL+0.91EQL  
42) 1.00 0.53SW+0.53RDL+0.91EQR  
43) 1.00 0.53SW+0.53RDL+0.91EQB+NLL  
44) 1.00 0.53SW+0.53RDL+0.91EQB+NLR  
45) 1.00 0.53SW+0.53RDL+0.91EQF

# FRAME LINE 2-6

Job : C22B0182A      Rob Kerth Iceland  
 Frame: F01

NUCOR BUILDINGS GROUP

Date: 08-24-22  
 By : BG\Viviana.Perez

Page: 1  
 File: F01A

\*\*\* DESIGN SUMMARY REPORT \*\*\*

Built Up Rafter - RAF01

Section	T/L	B/R	Load	Comb	Loc	Axial Kips	Axial Ratio	Moment Ft-kip	T/L	B/R	Max Unity Check	SHEAR					
	Flange Mat'l	Flange Mat'l							Web Mat'l	Bend Ratio		Bend Ratio	Load Comb	Loc	Force Kips	Shear Ratio	Flow (k/in) T/L B/R
1	F8.31	F8.50	W188	3	1	-27.5	0.13	-382.4	1.00	0.87	0.94	3	1	21.69	0.53	0.45	0.56

Chkpt            1                            5  
 Depth 36.81                            24.81  
 Section |                            1                            |

| width thick    Fy    |

T/L Flg | 8.0 0.3125 55.00 |  
 Web    |            0.1875 55.00 |  
 B/R Flg | 8.0 0.5000 55.00 |

Built Up Rafter - RAF02

Section	T/L	B/R	Load	Comb	Loc	Axial Kips	Axial Ratio	Moment Ft-kip	T/L	B/R	Max Unity Check	SHEAR					
	Flange Mat'l	Flange Mat'l							Web Mat'l	Bend Ratio		Bend Ratio	Load Comb	Loc	Force Kips	Shear Ratio	Flow (k/in) T/L B/R
1	F6.31	F6.38	W135	3	6	-26.1	0.31	-103.3	0.64	0.77	0.99	3	6	15.13	0.73	0.48	0.52
2	F6.31	F6.38	W188	4	14	-24.8	0.27	136.7	0.84	0.71	1.02	3	12	4.99	0.12	0.14	0.16

Chkpt            6                            11    12                            16  
 Depth 24.69                            24.69                            24.69  
 Section |                            1                            |                            2                            |

| width thick    Fy    | width thick    Fy    |

T/L Flg | 6.0 0.3125 55.00 | 6.0 0.3125 55.00 |  
 Web    |            0.1345 55.00 |            0.1875 55.00 |  
 B/R Flg | 6.0 0.3750 55.00 | 6.0 0.3750 55.00 |

Built Up Rafter - RAF03

Section	T/L	B/R	Load	Comb	Loc	Axial Kips	Axial Ratio	Moment Ft-kip	T/L	B/R	Max Unity Check	SHEAR					
	Flange Mat'l	Flange Mat'l							Web Mat'l	Bend Ratio		Bend Ratio	Load Comb	Loc	Force Kips	Shear Ratio	Flow (k/in) T/L B/R
1	F6.31	F6.38	W188	3	19	-24.8	0.27	137.9	0.85	0.72	1.02	4	21	-4.81	0.12	0.14	0.15
2	F6.31	F6.38	W135	3	22	-25.2	0.29	112.8	0.80	0.63	1.00	4	27	-14.95	0.72	0.47	0.51

Chkpt            17                            21    22                            27  
 Depth 24.69                            24.69                            24.69  
 Section |                            1                            |                            2                            |

| width thick    Fy    | width thick    Fy    |

T/L Flg | 6.0 0.3125 55.00 | 6.0 0.3125 55.00 |  
 Web    |            0.1875 55.00 |            0.1345 55.00 |  
 B/R Flg | 6.0 0.3750 55.00 | 6.0 0.3750 55.00 |

Built Up Rafter - RAF04

Section	T/L	B/R	Load	Comb	Loc	Axial Kips	Axial Ratio	Moment Ft-kip	T/L	B/R	Max Unity Check	SHEAR					
	Flange Mat'l	Flange Mat'l							Web Mat'l	Bend Ratio		Bend Ratio	Load Comb	Loc	Force Kips	Shear Ratio	Flow (k/in) T/L B/R
1	F8.31	F8.50	W188	4	32	-27.5	0.13	-380.7	1.00	0.86	0.93	4	32	-21.55	0.53	0.45	0.55

Chkpt            28                            32  
 Depth 24.81                            36.81  
 Section |                            1                            |

| width thick    Fy    |

T/L Flg | 8.0 0.3125 55.00 |  
 Web    |            0.1875 55.00 |  
 B/R Flg | 8.0 0.5000 55.00 |

Built Up Column - COL01

Section	T/L	B/R	Load	Comb	Loc	Axial Kips	Axial Ratio	Moment Ft-kip	T/L	B/R	Max Unity Check	SHEAR					
	Flange Mat'l	Flange Mat'l							Web Mat'l	Bend Ratio		Bend Ratio	Load Comb	Loc	Force Kips	Shear Ratio	Flow (k/in) T/L B/R
1	F8.31	F8.50	W188	3	39	-29.0	0.13	-381.8	0.97	0.82	0.89	3	39	-22.86	0.56	1.67	1.88

Chkpt            33                            39  
 Depth 12.00                            37.81  
 Section |                            1                            |

| width thick    Fy    |

T/L Flg | 8.0 0.3125 55.00 |  
 Web    |            0.1875 55.00 |  
 B/R Flg | 8.0 0.5000 55.00 |

Built Up Column - COL02

# FRAME LINE 2-6

Section	Mat'l	T/L	B/R	Web	Load	Loc	Axial	Axial	Moment	T/L	B/R	Max	SHEAR			Flow (k/in)		
		Flange	Flange							Bend	Bend		Unity	Force	Shear	Flow	T/L	B/R
1	F8.50	F8.31	W188	4	47		-28.9	0.13	380.7	0.82	0.96	0.89	4	47	22.85	0.56	1.88	1.67

Chkpt	40	47
Depth	12.00	37.81
Section		

---

		width	thick	Fy	
--	--	-------	-------	----	--

---

T/L Flg		8.0	0.5000	55.00	
Web		0.1875	55.00		
B/R Flg		8.0	0.3125	55.00	

---

```

Frame Weight (lbs) = 4299
Deflections (in):
  10 yr Wind dx = 0.49 = H/ 402          LONG. WIND 2 TO FRONT
  Seismic dx = 1.00 = H/ 198          SEISMIC TO RIGHT
  Story Drift = 2.41 = 0.012H        SEISMIC TO RIGHT
Stability Coefficient = 0.01        1.07SW+1.07RDL+1.07COL+0.91EQB
Stability Ratio = 0.07             1.07SW+1.07RDL+1.07COL+0.91EQB
Fundamental Period = 0.7633        Single Story Period
  Maximum dx = -1.15 = H/ 172        1.07SW+1.07RDL+1.07COL+0.91EQL
  Maximum dy = -5.89 = L/ 203 @ MOD 1, SW+RDL+COL+RLL+RLR
  Max. Live dy = -3.42 = L/ 350 @ MOD 1, LIVE ON LEFT AND RIGHT
    
```

# FRAME LINE 2-6

F-16

## NUCOR BUILDINGS GROUP

Job # : C22B0182A  
 File : F01a.nfr  
 App Version : 1.6.127.0

Job Name : Rob Kerth Iceland  
 Designer : BG\Viviana.Perez  
 Date : 8/23/2022

Frame : F01

### BOLTED END-PLATES (BEP) SUMMARY

**Bolt Pre Tension Method : TurnOfNut**

#### PLATE SIZE: (in)

Splice ID	Left Type	Right Type	Members Joined	Web Loc	Web Depth	Left Plate				Right Plate			
						Width	Thick	Length	Fy(ksi)	Width	Thick	Length	Fy(ksi)
1	6E	6E	COL01 To RAF01	Top	36.00	8.00	0.63	42.37	55.0	8.00	0.63	42.37	55.0
1	6E	6E	COL01 To RAF01	Bot	36.00	8.00	0.63	42.37	55.0	8.00	0.63	42.37	55.0
2	6E	6E	RAF01 To RAF02	Top	24.00	8.00	0.50	30.25	55.0	6.00	0.38	30.25	55.0
2	6E	6E	RAF01 To RAF02	Bot	24.00	8.00	0.50	30.25	55.0	6.00	0.38	30.25	55.0
3	4E	4E	RAF02 To RAF03	Top	24.00	6.00	0.50	30.08	55.0	6.00	0.50	30.08	55.0
3	4E	4E	RAF02 To RAF03	Bot	24.00	6.00	0.50	30.08	55.0	6.00	0.50	30.08	55.0
4	4E	4E	RAF03 To RAF04	Top	24.00	6.00	0.38	30.25	55.0	8.00	0.50	30.25	55.0
4	4E	4E	RAF03 To RAF04	Bot	24.00	6.00	0.38	30.25	55.0	8.00	0.50	30.25	55.0
5	6E	6E	RAF04 To COL02	Top	36.00	8.00	0.63	42.37	55.0	8.00	0.63	42.37	55.0
5	6E	6E	RAF04 To COL02	Bot	36.00	8.00	0.63	42.37	55.0	8.00	0.63	42.37	55.0

#### PLATE DESIGN

Splice ID	Left Type	Right Type	Tension Location	Load Comb	Max Moment			Max Shear				Left Plate Ratio	Right Plate Ratio
					Axial (kip)	Shear (kip)	Moment (ft-kip)	Load Comb	Axial (kip)	Shear (kip)	Moment (ft-kip)		
1	6E	6E	Top	2	-24.72	24.86	-382.37	10	9.39	-11.18	161.79	0.86	0.86
1	6E	6E	Bot	10	9.39	-11.18	161.79	2	-24.72	24.86	-382.37	0.44	0.43
2	6E	6E	Top	2	-26.07	15.19	-103.27	10	10.37	-6.85	37.68	0.44	0.96
2	6E	6E	Bot	22	12.31	-5.32	52.90	2	-26.07	15.19	-103.27	0.37	0.81
3	4E	4E	Top	8	10.64	-0.93	-45.66	15	-3.07	1.58	24.96	0.44	0.44
3	4E	4E	Bot	2	-24.72	0.07	134.42	22	12.38	-1.58	-41.86	0.84	0.84
4	4E	4E	Top	2	-26.06	-15.01	-96.56	8	10.38	6.78	35.25	1.00	0.45
4	4E	4E	Bot	20	12.14	5.27	50.93	2	-26.06	-15.01	-96.56	0.89	0.39
5	6E	6E	Top	2	-24.72	-24.69	-380.68	8	9.42	11.10	161.73	0.86	0.86
5	6E	6E	Bot	8	9.42	11.10	161.73	2	-24.72	-24.69	-380.68	0.43	0.44

#### BOLT RUPTURE DESIGN

Splice ID	Left Type	Right Type	Bolt Loc	Pre-Tension	Dia	Gage	Gage 2	Pfi	Pfo	Pf	Pb	de	Load Comb	Axial (kip)	Moment (ft-kip)	Left Bolt Ratio	Right Bolt Ratio	
																		1
1	6E	6E	Bot	A325	Yes	0.75	3.50	--	1.38	1.50	3.25	2.25	1.25	10	9.39	161.79	0.50	0.50
2	6E	6E	Top	A325	Yes	0.75	3.50	--	1.25	1.56	3.13	2.25	1.25	2	-26.07	-103.27	0.33	0.46
2	6E	6E	Bot	A325	Yes	0.75	3.50	--	1.25	1.34	3.13	2.25	1.25	22	12.31	52.90	0.28	0.28
3	4E	4E	Top	A325	Yes	0.75	3.50	--	1.25	1.48	3.00	--	1.25	8	10.64	-45.66	0.35	0.35
3	4E	4E	Bot	A325	Yes	0.75	3.50	--	1.25	1.33	3.00	--	1.25	2	-24.72	134.42	0.67	0.67
4	4E	4E	Top	A325	Yes	0.75	3.50	--	1.25	1.56	3.13	--	1.25	2	-26.06	-96.56	0.59	0.43
4	4E	4E	Bot	A325	Yes	0.75	3.50	--	1.25	1.50	3.13	--	1.25	20	12.14	50.93	0.39	0.39
5	6E	6E	Top	A325	Yes	0.75	3.50	--	1.38	1.51	3.25	2.25	1.25	2	-24.72	-380.68	0.98	0.98
5	6E	6E	Bot	A325	Yes	0.75	3.50	--	1.38	1.46	3.25	2.25	1.25	8	9.42	161.73	0.50	0.50

#### COMBINED BOLT BEARING SHEAR DESIGN

Splice ID	Left Type	Right Type	Bolt Loc	Pre-Tension	Dia	Gage	Gage 2	Pfi	Pfo	Pf	Pb	de	Load Comb	Shear (kip)	Left Bolt Ratio	Right Bolt Ratio	
																	1
1	6E	6E	Bot	A325	Yes	0.75	3.50	--	1.38	1.50	3.25	2.25	1.25	2	24.86	0.35	0.35
2	6E	6E	Top	A325	Yes	0.75	3.50	--	1.25	1.56	3.13	2.25	1.25	10	-6.85	0.10	0.10

Splice ID	Left Type	Right Type	Bolt Loc	Bolt Type	Pre-Tension	Dia	Gage	Gage 2	Pfi	Pfo	Pf	Pb	de	Load Comb	Shear (kip)	Left Bolt	Right Bolt
																Ratio	Ratio
2	6E	6E	Bot	A325	Yes	0.75	3.50	--	1.25	1.34	3.13	2.25	1.25	2	15.19	0.21	0.21
3	4E	4E	Top	A325	Yes	0.75	3.50	--	1.25	1.48	3.00	--	1.25	15	1.58	0.03	0.03
3	4E	4E	Bot	A325	Yes	0.75	3.50	--	1.25	1.33	3.00	--	1.25	22	-1.58	0.03	0.03
4	4E	4E	Top	A325	Yes	0.75	3.50	--	1.25	1.56	3.13	--	1.25	8	6.78	0.14	0.14
4	4E	4E	Bot	A325	Yes	0.75	3.50	--	1.25	1.50	3.13	--	1.25	2	-15.01	0.31	0.31
5	6E	6E	Top	A325	Yes	0.75	3.50	--	1.38	1.51	3.25	2.25	1.25	8	11.10	0.16	0.16
5	6E	6E	Bot	A325	Yes	0.75	3.50	--	1.38	1.46	3.25	2.25	1.25	2	-24.69	0.35	0.35

WELD DESIGN

Splice ID	Loc	Left						Right							
		Welds			Checks			Welds			Checks				
		Flg	Web	Stf	Load Comb	Tensile Rupture	Load Comb	Shear Rupture	Flg	Web	Stf	Load Comb	Tensile Rupture	Load Comb	Shear Rupture
1	Top	FWD4	WP13		2	0.87	10	0.17	FWD4	WP13		2	0.96	10	0.16
1	Bot	FWD3	WP13		10	0.51	2	0.37	FWD3	WP13		10	0.57	2	0.37
2	Top	FWD3	WP13		2	0.38	10	0.14	FWD3	WP13		2	0.53	10	0.20
2	Bot	FWD3	WP13		22	0.32	2	0.32	FWD3	WP13		22	0.45	2	0.45
3	Top	FWD3	WP13		8	0.40	15	0.04	FWD3	WP13		8	0.40	15	0.04
3	Bot	FWD3	WP13		2	0.77	22	0.04	FWD3	WP13		2	0.77	22	0.04
4	Top	FWD3	WP13		2	0.54	8	0.20	FWD3	WP13		2	0.39	8	0.15
4	Bot	FWD3	WP13		20	0.49	2	0.44	FWD3	WP13		20	0.35	2	0.34
5	Top	FWD4	WP13		2	0.95	8	0.16	FWD4	WP13		2	0.87	8	0.16
5	Bot	FWD3	WP13		8	0.57	2	0.37	FWD3	WP13		8	0.51	2	0.36

BASEPLATE AND ANCHOR ROD DESIGN RESULTS

BASEPLATE AND ANCHOR ROD INFORMATION: (in)

Column ID	Column Type	Column Pattern	Column Depth	Base Plate				Anchor Rods					
				Width	Thickness	Length	Fy(ksi)	Qty	Dia.	Grade	Pfi	Pb	Gage
COL01	WF/BU	Left	12	10	0.625	12.0000	55	4	1.25	Grade36	4	5	5
COL02	WF/BU	Right	12	10	0.625	12.0000	55	4	1.25	Grade36	4	5	5

BASEPLATE DESIGN CHECKS

Column ID	Concrete Bearing (Compression)					Base Plate Yielding (Tension)				
	Load Comb	Axial (kip)	Shear (kip)	Bracing Shear (kip)	Design Ratio	Load Comb	Axial (kip)	Shear (kip)	Bracing Shear (kip)	Design Ratio
COL01	2	-28.00	-24.80	0.00	0.15	10	12.07	10.76	0.00	0.68
COL02	2	-27.84	24.78	0.00	0.15	22	14.05	-7.36	-3.30	0.73

ANCHOR ROD SHEAR AND TENSION DESIGN CHECKS

Column ID	Anchor Rod Tension Design				Anchor Rod Shear Design				Combined Tension-Shear Design				Combined Shear-Tension Design			
	Load Comb	Axial (kip)	Shear (kip)	Bracing Shear (kip)	Load Comb	Axial (kip)	Shear (kip)	Bracing Shear (kip)	Load Comb	Axial (kip)	Shear (kip)	Bracing Shear (kip)	Load Comb	Axial (kip)	Shear (kip)	Bracing Shear (kip)
COL01	10	12.07	10.76	0.00	2	-28.00	-24.80	0.00	10	12.07	10.76	0.00	2	-28.00	-24.80	0.00
COL02	22	14.05	-7.36	-3.30	2	-27.84	24.78	0.00	22	14.05	-7.36	-3.30	2	-27.84	24.78	0.00

BASEPLATE LEFT FLANGE WELD DESIGN CHECKS

Column ID	Left Flange Weld (Pipe Weld)						Web Weld					Right Flange Weld						
	Weld Size	Load Comb	Axial (kip)	Shear (kip)	Bracing Shear (kip)	Weld Ratio	Weld Size	Load Comb	Axial (kip)	Shear (kip)	Bracing Shear (kip)	Weld Ratio	Weld Size	Load Comb	Axial (kip)	Shear (kip)	Bracing Shear (kip)	Weld Ratio
COL01	FWS3	-74	7.68	-3.91	-16.63	0.57	FWR3	2	-28.00	-24.80	0.00	0.56	FWS3	-74	7.68	-3.91	-16.63	0.32
COL02	FWS3	-71	7.72	3.90	-16.63	0.32	FWR3	2	-27.84	24.78	0.00	0.56	FWS3	-71	7.72	3.90	-16.63	0.57

No	ASR	Combination
1	1.00	1.00SW+1.00RDL+1.00COL
2	1.00	1.00SW+1.00RDL+1.00COL+1.00RLL+1.00RLR
3	1.00	1.00SW+1.00RDL+1.00COL+0.60W1L
4	1.00	1.00SW+1.00RDL+1.00COL+0.60W2L
5	1.00	1.00SW+1.00RDL+1.00COL+0.60W1R
6	1.00	1.00SW+1.00RDL+1.00COL+0.60W2R
7	1.00	0.60SW+0.60RDL+0.60W1L
8	1.00	0.60SW+0.60RDL+0.60W2L
9	1.00	0.60SW+0.60RDL+0.60W1R
10	1.00	0.60SW+0.60RDL+0.60W2R
11	1.00	1.00SW+1.00RDL+1.00COL+0.75RLL+0.75RLR+0.45W1L
12	1.00	1.00SW+1.00RDL+1.00COL+0.75RLL+0.75RLR+0.45W2L
13	1.00	1.00SW+1.00RDL+1.00COL+0.75RLL+0.75RLR+0.45W1R
14	1.00	1.00SW+1.00RDL+1.00COL+0.75RLL+0.75RLR+0.45W2R
15	1.00	1.00SW+1.00RDL+1.00COL+0.60W5B+0.60BWB
16	1.00	1.00SW+1.00RDL+1.00COL+0.60W6B+0.60BWB
17	1.00	1.00SW+1.00RDL+1.00COL+0.60W5F+0.60BWF
18	1.00	1.00SW+1.00RDL+1.00COL+0.60W6F+0.60BWF
19	1.00	0.60SW+0.60RDL+0.60W5B+0.60BWB
20	1.00	0.60SW+0.60RDL+0.60W6B+0.60BWB
21	1.00	0.60SW+0.60RDL+0.60W5F+0.60BWF
22	1.00	0.60SW+0.60RDL+0.60W6F+0.60BWF
23	1.00	1.00SW+1.00RDL+1.00COL+0.75RLL+0.75RLR+0.45W5B+0.45BWB
24	1.00	1.00SW+1.00RDL+1.00COL+0.75RLL+0.75RLR+0.45W6B+0.45BWB
25	1.00	1.00SW+1.00RDL+1.00COL+0.75RLL+0.75RLR+0.45W5F+0.45BWF
26	1.00	1.00SW+1.00RDL+1.00COL+0.75RLL+0.75RLR+0.45W6F+0.45BWF
27	1.00	1.069SW+1.069RDL+1.069COL+0.91EQL
28	1.00	1.069SW+1.069RDL+1.069COL+0.91EQR
29	1.00	1.069SW+1.069RDL+1.069COL+0.91EQB
30	1.00	1.069SW+1.069RDL+1.069COL+0.91EQF
31	1.00	1.052SW+1.052RDL+1.052COL+0.682EQL
32	1.00	1.052SW+1.052RDL+1.052COL+0.682EQR
33	1.00	1.052SW+1.052RDL+1.052COL+0.682EQB
34	1.00	1.052SW+1.052RDL+1.052COL+0.682EQF
35	1.00	0.53SW+0.53RDL+0.91EQL
36	1.00	0.53SW+0.53RDL+0.91EQR
37	1.00	0.53SW+0.53RDL+0.91EQB
38	1.00	0.53SW+0.53RDL+0.91EQF
39*	1.20	1.069SW+1.069RDL+1.069COL+1.75EQL
40*	1.20	1.052SW+1.052RDL+1.052COL+1.313EQL
41*	1.20	0.531SW+0.531RDL+0.531COL+1.75EQL
42*	1.20	1.069SW+1.069RDL+1.069COL+1.75EQL+0.525EQB
43*	1.20	1.052SW+1.052RDL+1.052COL+1.313EQL+0.394EQB
44*	1.20	0.531SW+0.531RDL+0.531COL+1.75EQL+0.525EQB
45*	1.20	1.069SW+1.069RDL+1.069COL+1.75EQL+0.525EQF
46*	1.20	1.052SW+1.052RDL+1.052COL+1.313EQL+0.394EQF
47*	1.20	0.531SW+0.531RDL+0.531COL+1.75EQL+0.525EQF
48*	1.20	1.069SW+1.069RDL+1.069COL+1.75EQR
49*	1.20	1.052SW+1.052RDL+1.052COL+1.313EQR
50*	1.20	0.531SW+0.531RDL+0.531COL+1.75EQR

\*Indicates a Special Seismic Load Combination

No	ASR	Combination
51*	1.20	1.069SW+1.069RDL+1.069COL+1.75EQR+0.525EQB
52*	1.20	1.052SW+1.052RDL+1.052COL+1.313EQR+0.394EQB
53*	1.20	0.531SW+0.531RDL+0.531COL+1.75EQR+0.525EQB
54*	1.20	1.069SW+1.069RDL+1.069COL+1.75EQR+0.525EQF
55*	1.20	1.052SW+1.052RDL+1.052COL+1.313EQR+0.394EQF
56*	1.20	0.531SW+0.531RDL+0.531COL+1.75EQR+0.525EQF
57*	1.20	1.069SW+1.069RDL+1.069COL+1.40EQB
58*	1.20	1.052SW+1.052RDL+1.052COL+1.05EQB
59*	1.20	0.531SW+0.531RDL+0.531COL+1.40EQB
60*	1.20	1.069SW+1.069RDL+1.069COL+0.525EQL+1.75EQB
61*	1.20	1.052SW+1.052RDL+1.052COL+0.394EQL+1.313EQB
62*	1.20	0.531SW+0.531RDL+0.531COL+0.525EQL+1.75EQB
63*	1.20	1.069SW+1.069RDL+1.069COL+0.525EQR+1.75EQB
64*	1.20	1.052SW+1.052RDL+1.052COL+0.394EQR+1.313EQB
65*	1.20	0.531SW+0.531RDL+0.531COL+0.525EQR+1.75EQB
66*	1.20	1.069SW+1.069RDL+1.069COL+1.40EQF
67*	1.20	1.052SW+1.052RDL+1.052COL+1.05EQF
68*	1.20	0.531SW+0.531RDL+0.531COL+1.40EQF
69*	1.20	1.069SW+1.069RDL+1.069COL+0.525EQL+1.75EQF
70*	1.20	1.052SW+1.052RDL+1.052COL+0.394EQL+1.313EQF
71*	1.20	0.531SW+0.531RDL+0.531COL+0.525EQL+1.75EQF
72*	1.20	1.069SW+1.069RDL+1.069COL+0.525EQR+1.75EQF
73*	1.20	1.052SW+1.052RDL+1.052COL+0.394EQR+1.313EQF
74*	1.20	0.531SW+0.531RDL+0.531COL+0.525EQR+1.75EQF

\*Indicates a Special Seismic Load Combination



# FRAME LINE 2-6

F-20

Web Depth	7	36.00	8	24.00	9	24.00	CT	10	24.00	11	24.00	CT	12	24.00	13	36.00
Length on Slope		180.00		240.00		163.01		163.01		240.00				184.01		
Left/Top Flange		F8.31		F6.31		F6.31		F6.31		F6.31				F8.31		
Web		W188		W135		W188		W188		W135				W188		
Right/Bottom Flange		F8.50		F6.38		F6.38		F6.38		F6.38				F8.50		
Horizontal Tail Dim.				19.0315				52.5000						85.9685		
Purlin Offset: 8.0		RAF01				RAF02				RAF03				RAF04		
Projected Area: 304																

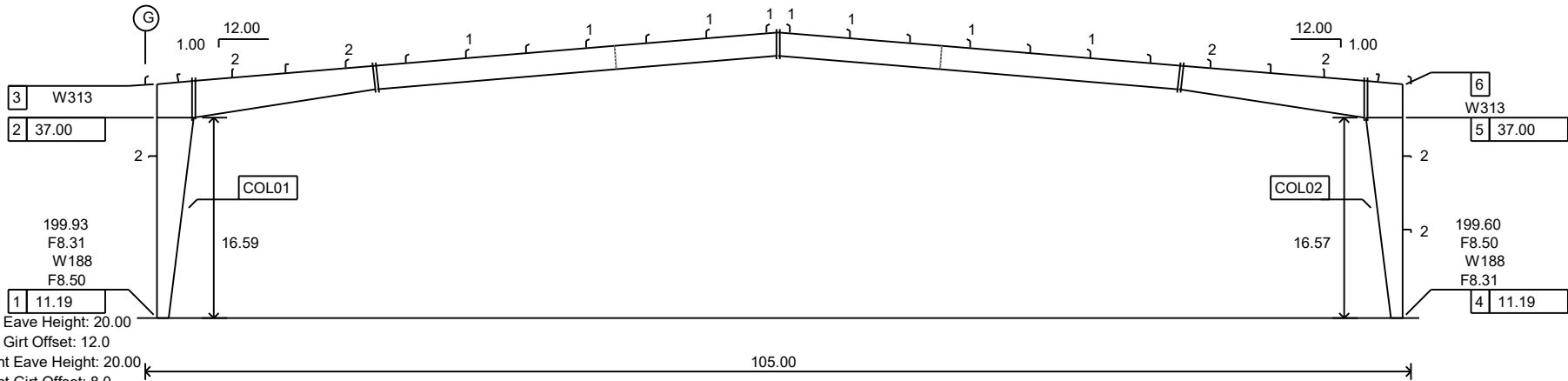

Left Eave Height: 20.00	Left Girt Offset: 12.0	Right Eave Height: 20.00	Right Girt Offset: 8.0	Total Width: 105.00	Frame Wt: 5385	Max Wind dx: H/400	Max dx: H/199	Max dy: L/203					
Location Code	1 P	2	3	4 P	5	6	7 M	8 M	9	10 M	11	12 M	13 M
Left Plate	NA	4x0.375	8x0.313	NA	4x0.375	8x0.313	8x0.625	8x0.500	-	6x0.500	-	6x0.375	8x0.625
Right Plate	10x0.625	-	-	10x0.625	-	-	8x0.625	6x0.375	-	6x0.500	-	8x0.500	8x0.625
Bolt Quantity-Diameter	4-1.250	-	-	4-1.250	-	-	12-0.75-S	12-0.75-S	-	8-0.75-S	-	8-0.75-S	12-0.75-S
Pfi/Pf	4.000/NA	-	-	4.000/NA	-	-	1.375/3.250	1.250/3.125	-	1.250/3.000	-	1.250/3.125	1.375/3.250
Top Welds (L/R)	FWS3	-	W1-FWS3	FWS3	-	W1-FWS3	FWD4/FWD4	FWD3/FWD3	-	FWD3/FWD3	-	FWD3/FWD3	FWD4/FWD4
Bottom Welds (L/R)	FWS3	-	W3-FWS4	FWS3	-	W3-FWS4	FWD3/FWD3	FWD3/FWD3	-	FWD3/FWD3	-	FWD3/FWD3	FWD3/FWD3
Web Welds (L/R)	FWR3	-	W4-FWS3	FWR3	-	W4-FWS3	WP13/WP13	WP13/WP13	-	WP13/WP13	-	WP13/WP13	WP13/WP13
Connection Code	BHFCNA	-	-	BHFCNA	-	-	KVEUEU	SPEUEU	-	SVEUEU	-	SPEUEU	KVEUEU
Pb/Gage	5.000/5.000	-	-	5.000/5.000	-	-	2.250/3.500	2.250/3.500	-	NA/3.500	-	NA/3.500	2.250/3.500

B01  
C22B0182a  
Roof Plan

Viviana.Perez  
8/22/2022

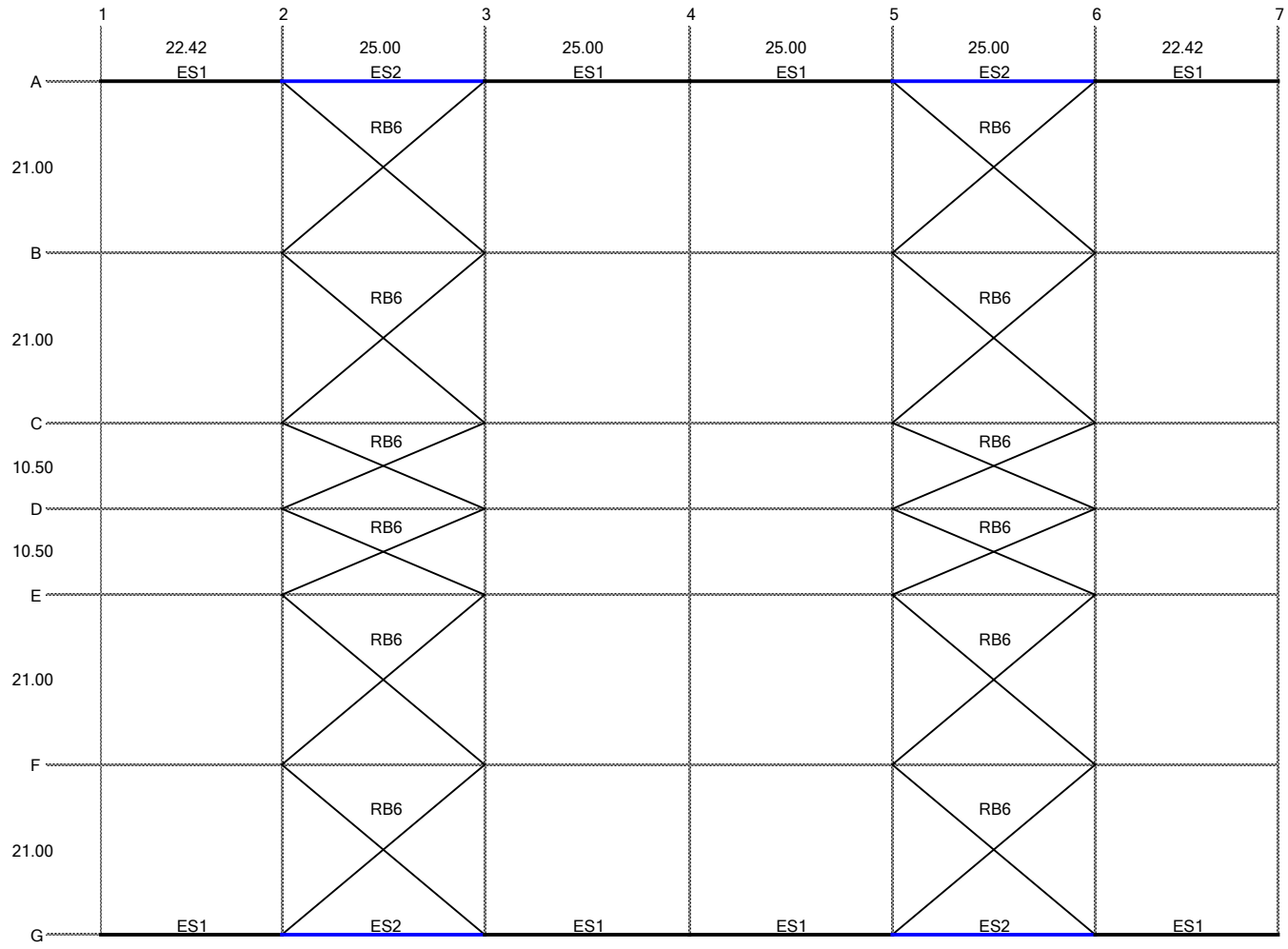

~~RB6 - 3/4 ROD~~  
~~ES2 - PG-189 PipeStrut + 9E060 w/ std. (2) bolt connx.~~  
AC-13 clip w/ 12ga strut purlin 1' uphill

ES1 - 8E060B2 - EaveStrut w/ std. (2)-bolt connx.

B01  
C22B0182a  
Sidewall Elevations - Bldg. A

Viviana.Perez  
8/22/2022

Front Sidewall

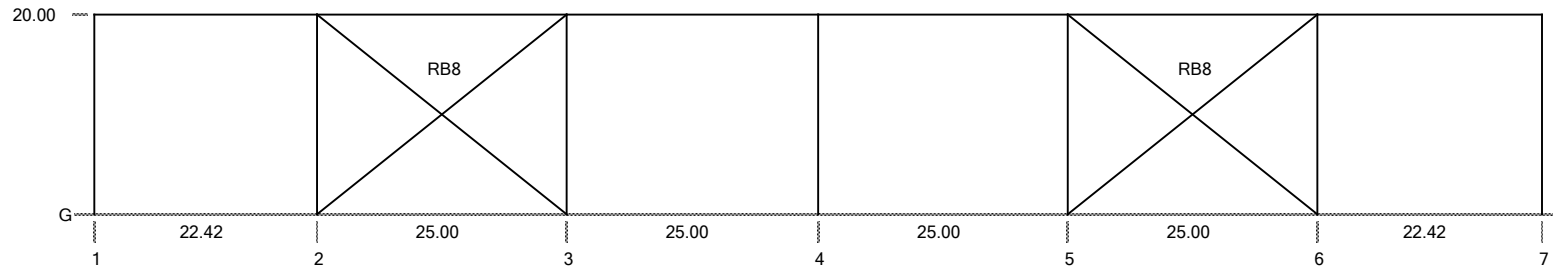

RB8 - 1 ROD



Back Sidewall

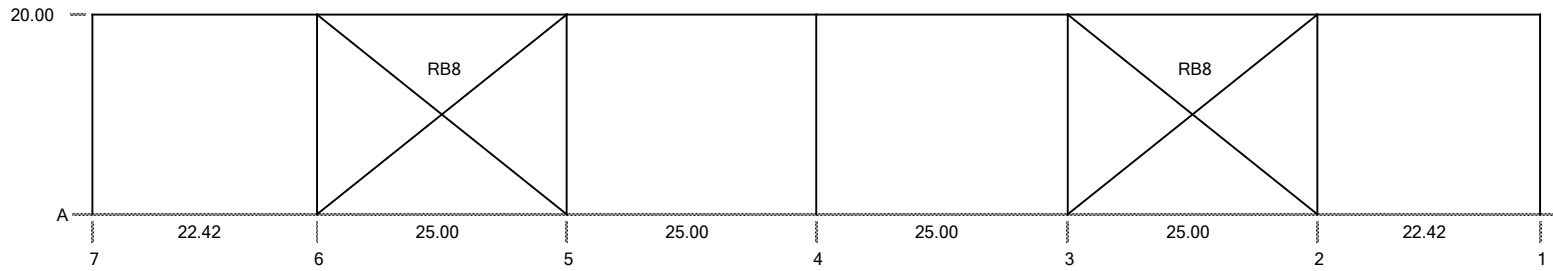

RB8 - 1 ROD



-----  
 INPUT REPORT  
 -----

NUCOR BUILDINGS GROUP  
 Job Name: Ice Land  
 Designer: Viviana.Perez  
 File : B01.nbr

BRACING PROGRAM  
 Job Number : C22B0182a  
 Date : 8/22/2022  
 App Version: 1.5.98.0

-----  
 STRUCTURAL GEOMETRY  
 -----

Building Width :	105.00 Ft.	Building Length :	144.84 Ft.
BSW Eave Ht :	20.00 Ft.	Left Roof Slope :	1.00/12
FSW Eave Ht :	20.00 Ft.	Right Roof Slope :	1.00/12
Girt Offset :	8.00 In.	Purlin Offset :	8.00 In.
Ridge Location :	52.50 Ft.		

Main Frame Spans: 105.0000'  
 Bay Spacing : 22.4200', 4@25.0000', 22.4200'

Endwall Spacing -> Left : 2@21.0000', 2@10.5000', 2@21.0000'  
 Right: 2@21.0000', 2@10.5000', 2@21.0000'

Girt Spacings -> BSW : 7.5000', 6.0000', 3.2500'  
 FSW : 7.5000', 6.0000', 3.2500'

Purlin Spacing -> RP1 : 1.0000', 10@5.0000', 1.6820'  
 RP2 : 1.0000', 10@5.0000', 1.6820'

Roof Connection Type: Bolted

-----  
 LOADING CONDITIONS  
 -----

Building Code & Year : IBC 2018  
 Risk Category : III-Substantial Hazard

-----  
 GRAVITY LOADING (DEAD, LIVE AND SNOW)  
 -----

Roof Dead Load = 2.50 PSF	Roof Col. Load = 5.00 PSF	Roof Live Load = 12.00 PSF
Ground Snow = 0.00 PSF	Roof Snow Load = 0.00 PSF	Is Slippery = False
Roof Exp. (Ce) = 1.0	Thermal Con. (Ct) = 1.0	Slope Factor (Cs) = 1.00

-----  
 SEISMIC  
 -----

Site Class: D Longitudinal Framing System: Braced Bays

Seismic Data:

Ss = 0.539	S1 = 0.246	Seismic Dead Wt = 13.15 PSF
Sds = 0.492	Sd1 = 0.346	Total Seismic Wt = 13.15 PSF

rho = 1.30                      omega = 2.00                      R = 3.25

Roof Seismic Factor = 0.189      Design Category = D                      Roof Diaphragm = Flexible  
 Irregular Building = False

-----  
 WIND  
 -----

Wind Speed : 110 MPH                      Wind Exposure: C                      Wind Enclosure: Enclosed  
 MRH Pressure: 23.75 PSF

-----  
 WIND PRESSURE COEFFICIENTS  
 -----

	C5	C6	C5E	C6E	Net Pressure On Building	
W5B	0.580	-0.110	0.790	-0.250	W5B (PSF)	17.88
W5F	-0.110	0.580	-0.250	0.790	W5F (PSF)	-17.88

-----  
 Wind Pressures  
 -----

	Interior Zone		Exterior Zone		To Elev. (Ft.)	Parapet Wind Pressure	
	W5B (PSF)	W5F (PSF)	W5B (PSF)	W5F (PSF)		Left Endwall	Right Endwall
Windward	13.77	13.77	18.76	18.76	24.38	Windward --- (PSF)	--- (PSF)
Leeward	-2.61	-2.61	-5.94	-5.94	---	Leeward --- (PSF)	--- (PSF)

-----  
 USER-APPLIED LOADS  
 -----

Load Case (ID)	Roof/Wall (ID)	Load Dir. (X,Z)	Load Magnitude (Kips)	Frame Line (ID)	Roof Grid (ID)	Wall Elevation (Ft.)	Description

-----  
 LOAD COMBINATIONS  
 -----

ID	ASR	Name
1)	1.00	SW+RDL+COL+0.60W5B
2)	1.00	SW+RDL+COL+0.60W5F
3)	1.00	0.60SW+0.60RDL+0.60W5B
4)	1.00	0.60SW+0.60RDL+0.60W5F
5)	1.00	SW+RDL+COL+0.75RLL+0.45W5B

6)	1.00	SW+RDL+COL+0.75RLL+0.45W5F
7)	1.00	1.07SW+1.07RDL+1.07COL+0.91EQB
8)	1.00	1.07SW+1.07RDL+1.07COL+0.91EQF
9)	1.00	1.05SW+1.05RDL+1.05COL+0.68EQB
10)	1.00	1.05SW+1.05RDL+1.05COL+0.68EQF
11)	1.00	0.53SW+0.53RDL+0.91EQB
12)	1.00	0.53SW+0.53RDL+0.91EQF
13)	1.00	SW+RDL+COL+RLL+0.39NLB
14)	1.00	SW+RDL+COL+RLL-0.39NLB
15)	1.00	SW+RDL+COL+0.15NLB
16)	1.00	SW+RDL+COL-0.15NLB

-----  
 ^^^ REACTION REPORT -- BY LOAD CASE ^^^  
 -----

 NUCOR BUILDINGS GROUP  
 Job Name: Ice Land  
 Designer: Viviana.Perez  
 File : B01.nbr

 BRACING PROGRAM  
 Job Number : C22B0182a  
 Date : 8/22/2022  
 App Version: 1.5.98.0  
 -----

 REACTIONS -- LOAD CASE W5B  
 -----

Frame Line	Grid Line	Horizontal + = right	Vertical + = up	Moment + = counterclockwise
1	A	0.00	0.00	0.00
1	G	0.00	0.00	0.00
2	A	-5.21	-4.16	0.00
2	G	-5.21	-4.16	0.00
3	A	0.00	4.16	0.00
3	G	0.00	4.16	0.00
4	A	0.00	0.00	0.00
4	G	0.00	0.00	0.00
5	A	-5.20	-4.16	0.00
5	G	-5.20	-4.16	0.00
6	A	0.00	4.16	0.00
6	G	0.00	4.16	0.00
7	A	0.00	0.00	0.00
7	G	0.00	0.00	0.00
Summation		-20.82	0.00	

 REACTIONS -- LOAD CASE W5F  
 -----

Frame Line	Grid Line	Horizontal + = right	Vertical + = up	Moment + = counterclockwise
1	A	0.00	0.00	0.00
1	G	0.00	0.00	0.00
2	A	0.00	4.16	0.00
2	G	0.00	4.16	0.00
3	A	5.20	-4.16	0.00
3	G	5.20	-4.16	0.00
4	A	0.00	0.00	0.00
4	G	0.00	0.00	0.00
5	A	0.00	4.16	0.00
5	G	0.00	4.16	0.00
6	A	5.21	-4.16	0.00
6	G	5.21	-4.16	0.00
7	A	0.00	0.00	0.00
7	G	0.00	0.00	0.00
Summation		20.82	0.00	

 REACTIONS -- LOAD CASE EQB  
 -----

Frame Line	Grid Line	Horizontal + = right	Vertical + = up	Moment + = counterclockwise
1	A	0.00	0.00	0.00
1	G	0.00	0.00	0.00
2	A	-9.44	-7.56	0.00
2	G	-9.44	-7.56	0.00
3	A	0.00	7.56	0.00
3	G	0.00	7.56	0.00
4	A	0.00	0.00	0.00
4	G	0.00	0.00	0.00
5	A	-9.44	-7.55	0.00
5	G	-9.44	-7.55	0.00
6	A	0.00	7.55	0.00
6	G	0.00	7.55	0.00
7	A	0.00	0.00	0.00
7	G	0.00	0.00	0.00
Summation		-37.77	0.00	

 REACTIONS -- LOAD CASE EQF  
 -----

Frame Line	Grid Line	Horizontal + = right	Vertical + = up	Moment + = counterclockwise
1	A	0.00	0.00	0.00
1	G	0.00	0.00	0.00
2	A	0.00	7.55	0.00
2	G	0.00	7.55	0.00
3	A	9.44	-7.55	0.00
3	G	9.44	-7.55	0.00
4	A	0.00	0.00	0.00
4	G	0.00	0.00	0.00

5	A	0.00	7.56	0.00
5	G	0.00	7.56	0.00
6	A	9.44	-7.56	0.00
6	G	9.44	-7.56	0.00
7	A	0.00	0.00	0.00
7	G	0.00	0.00	0.00
-----				
	Summation	37.77	0.00	

^^^ BRACING DESIGN SUMMARY REPORT -- BY CONTROLLING LOAD COMBINATION ^^^

NUCOR BUILDINGS GROUP  
 Job Name: Ice Land  
 Designer: Viviana.Perez  
 File : B01.nbr

BRACING PROGRAM  
 Job Number : C22B0182a  
 Date : 8/22/2022  
 App Version: 1.5.98.0

BRACES

Memb. ID	Frame Lines	Grid/ Top Elev.	Orient.	Mat. code	Member desc.	Load comb.	Axial (k)	Axial Allowed	Min tw	Omega Applied
B1	2-3	A-B	/	RB6	3/4_ROD	8	9.10	10.89	0.115	TW ONLY
B2	2-3	A-B	\	RB6	3/4_ROD	7	9.10	10.89	0.115	TW ONLY
B3	2-3	B-C	/	RB6	3/4_ROD	8	4.55	10.89	0.056	TW ONLY
B4	2-3	B-C	\	RB6	3/4_ROD	7	4.55	10.89	0.056	TW ONLY
B5	2-3	C-D	/	RB6	3/4_ROD	8	0.94	10.89	0.007	TW ONLY
B6	2-3	C-D	\	RB6	3/4_ROD	7	0.94	10.89	0.007	TW ONLY
B7	2-3	D-E	/	RB6	3/4_ROD	7	0.94	10.89	0.007	TW ONLY
B8	2-3	D-E	\	RB6	3/4_ROD	8	0.94	10.89	0.007	TW ONLY
B9	2-3	E-F	/	RB6	3/4_ROD	7	4.55	10.89	0.056	TW ONLY
B10	2-3	E-F	\	RB6	3/4_ROD	8	4.55	10.89	0.056	TW ONLY
B11	2-3	F-G	/	RB6	3/4_ROD	7	9.10	10.89	0.115	TW ONLY
B12	2-3	F-G	\	RB6	3/4_ROD	8	9.10	10.89	0.115	TW ONLY
B13	5-6	A-B	/	RB6	3/4_ROD	8	9.10	10.89	0.115	TW ONLY
B14	5-6	A-B	\	RB6	3/4_ROD	7	9.10	10.89	0.115	TW ONLY
B15	5-6	B-C	/	RB6	3/4_ROD	8	4.55	10.89	0.056	TW ONLY
B16	5-6	B-C	\	RB6	3/4_ROD	7	4.55	10.89	0.056	TW ONLY
B17	5-6	C-D	/	RB6	3/4_ROD	8	0.94	10.89	0.007	TW ONLY
B18	5-6	C-D	\	RB6	3/4_ROD	7	0.94	10.89	0.007	TW ONLY
B19	5-6	D-E	/	RB6	3/4_ROD	7	0.94	10.89	0.007	TW ONLY
B20	5-6	D-E	\	RB6	3/4_ROD	8	0.94	10.89	0.007	TW ONLY
B21	5-6	E-F	/	RB6	3/4_ROD	7	4.55	10.89	0.056	TW ONLY
B22	5-6	E-F	\	RB6	3/4_ROD	8	4.55	10.89	0.056	TW ONLY
B23	5-6	F-G	/	RB6	3/4_ROD	7	9.10	10.89	0.115	TW ONLY
B24	5-6	F-G	\	RB6	3/4_ROD	8	9.10	10.89	0.115	TW ONLY
B25	2-3	A 20.00	/	RB8	1_ROD	7	17.18	22.92	0.150	Y
B26	2-3	A 20.00	\	RB8	1_ROD	8	17.17	22.92	0.150	Y
B27	5-6	A 20.00	/	RB8	1_ROD	7	17.17	22.92	0.150	Y
B28	5-6	A 20.00	\	RB8	1_ROD	8	17.18	22.92	0.150	Y
B29	2-3	G 20.00	/	RB8	1_ROD	7	17.18	22.92	0.150	Y
B30	2-3	G 20.00	\	RB8	1_ROD	8	17.17	22.92	0.150	Y
B31	5-6	G 20.00	/	RB8	1_ROD	7	17.17	22.92	0.150	Y
B32	5-6	G 20.00	\	RB8	1_ROD	8	17.18	22.92	0.150	Y

The minimum web thickness (Min tw) provided for Single/DoubleX-Bracing clevis connections are based on the Standard Brace Clevis plate.

STRUTS

Memb. ID	Frame Lines	Grid/ Elev.	Mat. code	Member desc.	Load comb.	Axial (k)	Axial Allowed	Omega Applied
S1L	1-2	B	-4.38	PUR	1	-0.23		N
S1R	1-2	B	0.61	PUR	1	-1.66		N
S2L	1-2	C	-0.46	PUR	3	-1.39		N
S2R	1-2	C	4.52	PUR	3	-0.14		N
S3L	1-2	D	-1.00	PUR	1	-0.53		N
S3R	1-2	D	1.00	PUR	1	-0.53		N
S4L	1-2	E	-4.52	PUR	3	-0.14		N
S4R	1-2	E	0.46	PUR	3	-1.39		N
S5L	1-2	F	-0.61	PUR	1	-1.66		N
S5R	1-2	F	4.38	PUR	1	-0.23		N
S6L	2-3	B	-4.38	PUR	8	-0.64		N
S6R	2-3	B	0.61	PUR	8	-4.65		N
S7L	2-3	C	-0.46	PUR	8	-2.02		N
S7R	2-3	C	4.52	PUR	8	-0.21		N
S8L	2-3	D	-1.00	PUR	1	-0.53		N
S8R	2-3	D	1.00	PUR	1	-0.53		N
S9L	2-3	E	-4.52	PUR	8	-0.21		N
S9R	2-3	E	0.46	PUR	8	-2.02		N
S10L	2-3	F	-0.61	PUR	8	-4.65		N
S10R	2-3	F	4.38	PUR	8	-0.64		N
S11L	3-4	B	-4.38	PUR	1	-0.09		N
S11R	3-4	B	0.61	PUR	1	-0.67		N
S12L	3-4	C	-0.46	PUR	2	-0.56		N
S12R	3-4	C	4.52	PUR	2	-0.06		N
S13L	3-4	D	-1.00	PUR	1	-0.21		N
S13R	3-4	D	1.00	PUR	1	-0.21		N
S14L	3-4	E	-4.52	PUR	2	-0.06		N
S14R	3-4	E	0.46	PUR	2	-0.56		N
S15L	3-4	F	-0.61	PUR	1	-0.67		N
S15R	3-4	F	4.38	PUR	1	-0.09		N
S16L	4-5	B	-4.38	PUR	2	-0.09		N
S16R	4-5	B	0.61	PUR	2	-0.67		N
S17L	4-5	C	-0.46	PUR	1	-0.56		N
S17R	4-5	C	4.52	PUR	1	-0.06		N
S18L	4-5	D	-1.00	PUR	2	-0.21		N
S18R	4-5	D	1.00	PUR	2	-0.21		N
S19L	4-5	E	-4.52	PUR	1	-0.06		N
S19R	4-5	E	0.46	PUR	1	-0.56		N



S20L	4-5	F	-0.61	PUR		2	-0.67		N
S20R	4-5	F	4.38	PUR		2	-0.09		N
S21L	5-6	B	-4.38	PUR		7	-0.64		N
S21R	5-6	B	0.61	PUR		7	-4.65		N
S22L	5-6	C	-0.46	PUR		7	-2.02		N
S22R	5-6	C	4.52	PUR		7	-0.21		N
S23L	5-6	D	-1.00	PUR		2	-0.53		N
S23R	5-6	D	1.00	PUR		2	-0.53		N
S24L	5-6	E	-4.52	PUR		7	-0.21		N
S24R	5-6	E	0.46	PUR		7	-2.02		N
S25L	5-6	F	-0.61	PUR		7	-4.65		N
S25R	5-6	F	4.38	PUR		7	-0.64		N
S26L	6-7	B	-4.38	PUR		2	-0.23		N
S26R	6-7	B	0.61	PUR		2	-1.66		N
S27L	6-7	C	-0.46	PUR		4	-1.39		N
S27R	6-7	C	4.52	PUR		4	-0.14		N
S28L	6-7	D	-1.00	PUR		2	-0.53		N
S28R	6-7	D	1.00	PUR		2	-0.53		N
S29L	6-7	E	-4.52	PUR		4	-0.14		N
S29R	6-7	E	0.46	PUR		4	-1.39		N
S30L	6-7	F	-0.61	PUR		2	-1.66		N
S30R	6-7	F	4.38	PUR		2	-0.23		N
S31	1-2	A	20.00	8E060B2	EaveStrut	1	-1.18	2.48	Y
S32	2-3	A	20.00	<del>8E060B2</del>	<del>PipeStrut</del>	* 8	-12.11	24.60	Y
S32	2-3	A	20.00	8E060B2	EaveStrut				Y
S33	3-4	A	20.00	8E060B2	EaveStrut	1	-0.40	2.48	Y
S34	4-5	A	20.00	8E060B2	EaveStrut	2	-0.40	2.48	Y
S35	5-6	A	20.00	<del>8E060B2</del>	<del>PipeStrut</del>	* 7	-12.11	24.60	Y
S35	5-6	A	20.00	8E060B2	EaveStrut				Y
S36	6-7	A	20.00	8E060B2	EaveStrut	2	-1.18	2.48	Y
S37	1-2	G	20.00	8E060B2	EaveStrut	1	-1.18	2.48	Y
S38	2-3	G	20.00	<del>8E060B2</del>	<del>PipeStrut</del>	* 8	-12.11	24.60	Y
S38	2-3	G	20.00	8E060B2	EaveStrut				Y
S39	3-4	G	20.00	8E060B2	EaveStrut	1	-0.40	2.48	Y
S40	4-5	G	20.00	8E060B2	EaveStrut	2	-0.40	2.48	Y
S41	5-6	G	20.00	<del>8E060B2</del>	<del>PipeStrut</del>	* 7	-12.11	24.60	Y
S41	5-6	G	20.00	8E060B2	EaveStrut				Y
S42	6-7	G	20.00	8E060B2	EaveStrut	2	-1.18	2.48	Y

\*Use AC-13 clip  
w/ 12ga strut  
purlin 1' uphill

-----  
COST & WEIGHT SUMMARY  
IN DOLLARS & LBS  
-----

	Cables	Rods	Angles	Ev/Bx/Pi Struts	Purlin Struts	Portals	Total
COST	0	1224	0	2670	0	0	3895
WEIGHT	0	1858	0	2675	0	0	4534

-----  
SECOND ORDER ANALYSIS  
-----

Automatically Select 2nd Order Method

Load Combination	Sum Yi	Sum H	Delta	B2
1 SW+RDL+COL+0.60W5B	-38.2	12.50	0.211	1.00
2 SW+RDL+COL+0.60W5F	-38.2	-12.50	0.211	1.00
3 0.60SW+0.60RDL+0.60W5B	53.0	12.50	0.211	1.00
4 0.60SW+0.60RDL+0.60W5F	53.0	-12.50	0.211	1.00
5 SW+RDL+COL+0.75RLL+0.45W5B	-194.1	9.37	0.158	1.02
6 SW+RDL+COL+0.75RLL+0.45W5F	-194.1	-9.37	0.158	1.02
7 1.07SW+1.07RDL+1.07COL+0.91EQB	-121.9	26.46	0.461	1.01
8 1.07SW+1.07RDL+1.07COL+0.91EQF	-121.9	-26.46	0.461	1.01
9 1.05SW+1.05RDL+1.05COL+0.68EQB	-120.0	19.84	0.346	1.01
10 1.05SW+1.05RDL+1.05COL+0.68EQF	-120.0	-19.84	0.346	1.01
11 0.53SW+0.53RDL+0.91EQB	-20.1	26.46	0.461	1.00
12 0.53SW+0.53RDL+0.91EQF	-20.1	-26.46	0.461	1.00
13 SW+RDL+COL+RLL+0.39NLB	-296.6	0.59	0.010	1.04
14 SW+RDL+COL+RLL-0.39NLB	-296.6	-0.59	0.010	1.04
15 SW+RDL+COL+0.15NLB	-114.1	0.23	0.004	1.01
16 SW+RDL+COL-0.15NLB	-114.1	-0.23	0.004	1.01

-----



# STEEL BUILDINGS

a **NUCOR**® company  
www.cbcsteelbuildings.com

1700 E. Louise Avenue • Lathrop, CA 95330  
Tel: (209) 988-0910

Job: \_\_\_\_\_ Sheet No. **H-1**

Date: \_\_\_\_\_ By: \_\_\_\_\_

## HANG POST DESIGN

### Hang Post & Kicker

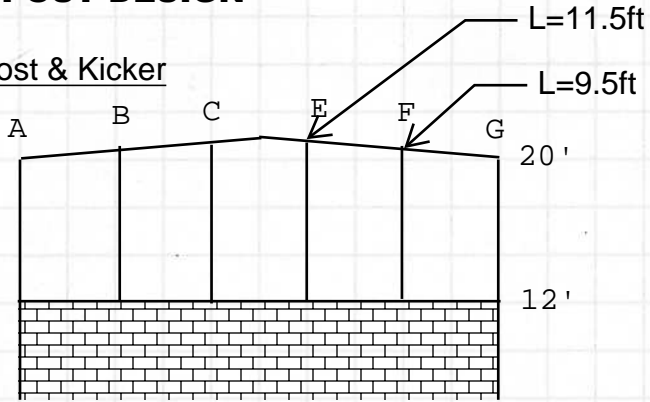

$$w = 23.75 \text{ psf} \cdot (21 \text{ ft}) \cdot (0.6) = 0.299 \text{ k/ft} \sim 0.3 \text{ k/ft}$$

$$V = 0.3 \text{ k/ft} \cdot (11.5 \text{ ft} / 2) = 1.73 \text{ k}$$

$$M = 0.3 \text{ k/ft} \cdot (11.5 \text{ ft})^2 / 8 = 4.95 \text{ k-ft} \sim 5 \text{ k-ft}$$

$$A_{\text{kicker}} = 1.73 \text{ k} / \cos(68^\circ) = 4.61 \text{ k} \sim 5 \text{ k}$$

$$\theta = 68^\circ$$

**Use Square Tube 4x4x1/4"**

**(Max  $L_c = 25 \text{ ft}$   $P_r / \omega = 13.0 \text{ kips}$ )**

### Longitudinal Beam

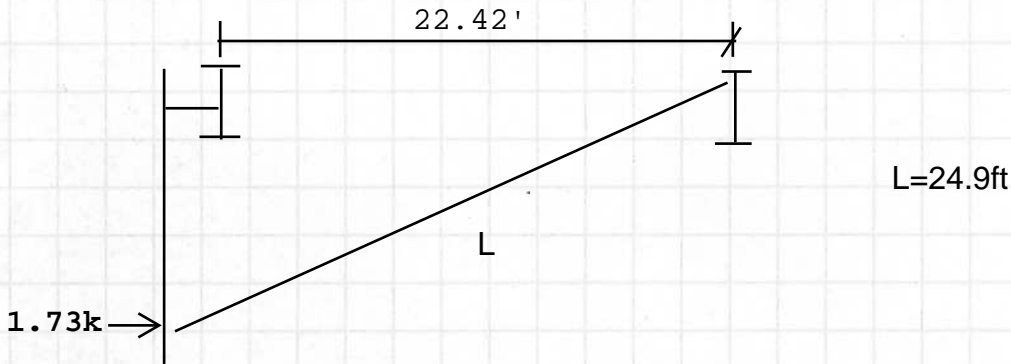

W8x10  
Bracket

(1) 3/8" PLs w/ (4) 1/2" A325

1.33'

22.42'

W8x10  
Hang  
post

22.5'

17.5'

15'

13.5'

12'

1/4"

3/8" PL w/ (2) 3/4"  
A325 & 1/4" stiff.  
under

4x4x1/4 Square Tube  
1/4" T clip

**BEAM-COLUMN S.S. (AISC 15th Edition)****MAIN REPORT: DESIGN SUMMARY**

Version: 2018.09.12 (Date: 09/12/18) By NBG-GS

GENERAL INFORMATION (ENTER DATA IN GRAY SHADED CELLS!)			Span and Loading Conditions				Remarks
			Hang				
			Post				
Member Length	$L_{bx}$	ft.	11.50				Assumes $L_{bx} = L$
Unbraced Length - Minor	$L_{by}$	ft.	5.00				
Consideration of <i>Tension Field Action</i> for Shear			FALSE	FALSE	FALSE	FALSE	<= See cell comment & Chapter G.
Clear Distance between Transverse Stiffeners	a	in.					<= See cell comment & Section G2.
Lateral-torsional buckling factor	$C_b$		1.000	1.000	1.000	1.000	<= See cell comment
Kx Factor	$K_x$		1.000	1.000	1.000	1.000	
Ky Factor	$K_y$		1.000	1.000	1.000	1.000	
Kz Factor	$K_z$		1.000	1.000	1.000	1.000	<= See cell comment
<b>SECTION GEOMETRY</b>							
Select Wide-flange or Built-up Section:			WF	None	None	None	
Section Description:			W8X10	--	--	--	
Enter WF-Section:			W8X10				
Total Depth	d	in.	7.890	--	--	--	
Web Thickness	$t_w$	in.	0.170	--	--	--	
Outside Flange Width	$b_{of}$	in.	3.940	--	--	--	
Outside Flange Thickness	$t_{of}$	in.	0.205	--	--	--	
Inside Flange Width	$b_{if}$	in.	3.940	--	--	--	
Inside Flange Thickness	$t_{if}$	in.	0.205	--	--	--	
<b>MATERIAL INFORMATION</b>							
Material Strength	$F_y$	ksi	50	50	50	55	
Elastic Modulus	E	ksi	29,000	29,000	29,000	29,000	Standard for steel shown
Shear Modulus	G	ksi	11,200	11,200	11,200	11,200	Standard for steel shown
Flange Yield Strength	$F_{yf}$	ksi	50	50	50	55	
Web Yield Strength	$F_{yw}$	ksi	50	50	50	55	
Ultimate Strength	$F_u$	ksi	65	65	65	70	
<b>APPLIED LOADS</b> <input type="checkbox"/> Applied Loading includes second order effects.							
Factor of Safety (Allowable Stress Factor)	$S_f$		1.000	1.000	1.000	1.000	
Axial (compression => + pos., tension => - neg.)	$P_a$	kips	1.000				
Shear (absolute value)	$V_x$	kips	1.730				Major Axis (x-axis)
Moment (outside flange in compression => + pos.)	$M_x$	ft-kip	5.000				
Shear (absolute value)	$V_y$	kips					Minor Axis (y-axis)
Moment (absolute value)	$M_y$	ft-kip					
<b>Design Results:</b>			<b>ASD</b>	<b>OK</b>	<b>--</b>	<b>--</b>	<b>Remarks</b>
ASD Combined Strength Ratio	CSR		0.284	--	--	--	Eq. H1-1a or H1-1b
ASD Shear Strength Ratio (x-axis)	$V_{rx}/V_{cx}$		0.074	--	--	--	Major Axis (x-axis)
ASD Shear Strength Ratio (y-axis)	$V_{ry}/V_{cy}$		0.000	--	--	--	Minor Axis (y-axis)
<b>Deflection Results (Major-axis)</b>			<b>OK</b>	<b>--</b>	<b>--</b>	<b>--</b>	<b>Remarks</b>
Deflection Limits (about x-axis)			L / 180	L / 180	L / 180	L / 180	Limits as numerals (i.e. 360 = L/360)
Maximum Deflection (about x-axis)	$\Delta_{max}$	in.	0.767 in.	0.000 in.	0.000 in.	0.000 in.	
Member Deflection (about x-axis)	$\Delta_{x-axis}$	in.	0.133 in.	--	--	--	$\Delta_{x-axis} \leq \Delta_{max}$
<b>Deflection Results (Minor-axis)</b>			<b>OK</b>	<b>--</b>	<b>--</b>	<b>--</b>	<b>Remarks</b>
Deflection Limits (about y-axis)			L / 180	L / 180	L / 180	L / 180	Limits as numerals (i.e. 360 = L/360)
Maximum Deflection (about y-axis)	$\Delta_{max}$	in.	0.767 in.	0.000 in.	0.000 in.	0.000 in.	
Member Deflection (about y-axis)	$\Delta_{y-axis}$	in.	0.000 in.	--	--	--	$\Delta_{y-axis} \leq \Delta_{max}$

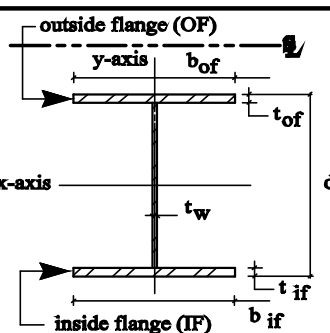



Project No.: C22B0182A  
 Project Name: Rob Kerth Ice Land  
 Engineer: VP  
 Date: 8/29/2022

## HSS Beam-Column (AISC 15th Ed.)

Version: 2020.05.18 (5/18/20) by NBG-GS

Span and Loading Information		Case 1	Case 2	Case 3	Case 4
Member Length	ft	24.9			
Unbraced Length - Major	in.	298.8	0	0	0
Unbraced Length - Minor	in.	298.8	0	0	0
Cbx	-	1	1	1	1
Cby	-	1	1	1	1
Cmx	-	1	1	1	1
Cmy	-	1	1	1	1
Kx	-	1	1	1	1
Ky	-	1	1	1	1
Shear Lag Factor 'U'	-	0.75	0.75	0.75	0.75
Applied Loads					
X-axis Uniform Load (+Dn)	kip/ft	0	0	0	0
Y-axis Uniform Load (+Dn)	kip/ft	0.01221	0	0	0
Axial Tension Load	kip	0	0	0	0
Axial Compression Load	kip	5	0	0	0
Mx End 1 (+=Ten. On Bot.)	ft-kip	0	0	0	0
Mx End 2 (+=Ten. On Bot.)	ft-kip	0	0	0	0
Mx Interior (+=Ten on Bot.)	ft-kip	0	0	0	0
My End 1 (+=Ten. On Bot.)	ft-kip	0	0	0	0
My End 2 (+=Ten. On Bot.)	ft-kip	0	0	0	0
My Interior (+=Ten on Bot.)	ft-kip	0	0	0	0
Vx Shear	kip	0	0	0	0
Vy Shear	kip	0	0	0	0
Torsion	ft-kip	0	0	0	0
Stress Factor	-	1	1	1	1
KL/r	-	197	---	---	---
	Result	OK	OK	OK	OK
	Max CSR	0.50	0.00	0.00	0.00
Section Information					
Section Type		Nucor Std. Tube ▼	Nucor Std. Pipe ▼	Nucor Std. Pipe ▼	Nucor Std. Pipe ▼
Section		T4.250 ▼	P6.134 ▼	P6.134 ▼	P6.134 ▼
Fy	ksi	46	42	42	42
Depth / Diameter	in.	4	6.625	6.625	6.625
Width / Diameter	in.	4	6.625	6.625	6.625
Design Thickness	in.	0.233	0.125	0.125	0.125
Design Loads					
Max Mx	ft-kip	0	0	0	0
Max My	ft-kip	0.946290263	0	0	0
Axial Tension	kip	0	0	0	0
Axial Compression	kip	5	0	0	0
Vx	kip	0	0	0	0
Vy	kip	0.1520145	0	0	0
Torsion	ft-kip	0	0	0	0
Stress Ratios					
Mx		0.000	0.000	0.000	0.000
My		0.089	0.000	0.000	0.000
Mx+My		0.089	0.000	0.000	0.000
Tension		0.000	0.000	0.000	0.000
P		0.381	0.000	0.000	0.000
M / P		0.498	0.000	0.000	0.000
Vx		0.000	0.000	0.000	0.000
Vy		0.006	0.000	0.000	0.000
M/V		0.089	0.000	0.000	0.000
Torsion		0.000	0.000	0.000	0.000
M/V/P/Torsion		0.470	0.000	0.000	0.000
M/V/Tension/Torsion		0.089	0.000	0.000	0.000
Deflection Results					
X-Axis Deflection	in.	0.000	0.000	0.000	0.000
L / X		N/A	N/A	N/A	N/A
Y-Axis Deflection	in.	0.467	0.000	0.000	0.000
L / Y		640	N/A	N/A	N/A